

## LOW FREQUENCY SOLAR INVERTER PV3900 TLV Series

12KW | 250V | 200A



PV3900 TLV series is a multi-function inverter, combining functions of inverter and MPPT solar charge controller, solar charger and battery charger to offer uninterruptible power support. The comprehensive LCD display offers user-configurable and easy-accessible button operation such as battery charging current, AC/solar charger priority, and selectable input voltage based on different applications.



- Smart LCD setting(Working modes, Charge Current, Charge voltage, etc.)
- Built-in MPPT solar charge controller 200A
- MPPT efficiency max 98%
- Powerful charge rate up to 200A
- Inside BMS function
- DC start & Automatic Self-Diagnostic Function
- WIFI monitoring function (optional)
- Compatible to generator
- Parallel operation with up to 3 units

### Back panel description

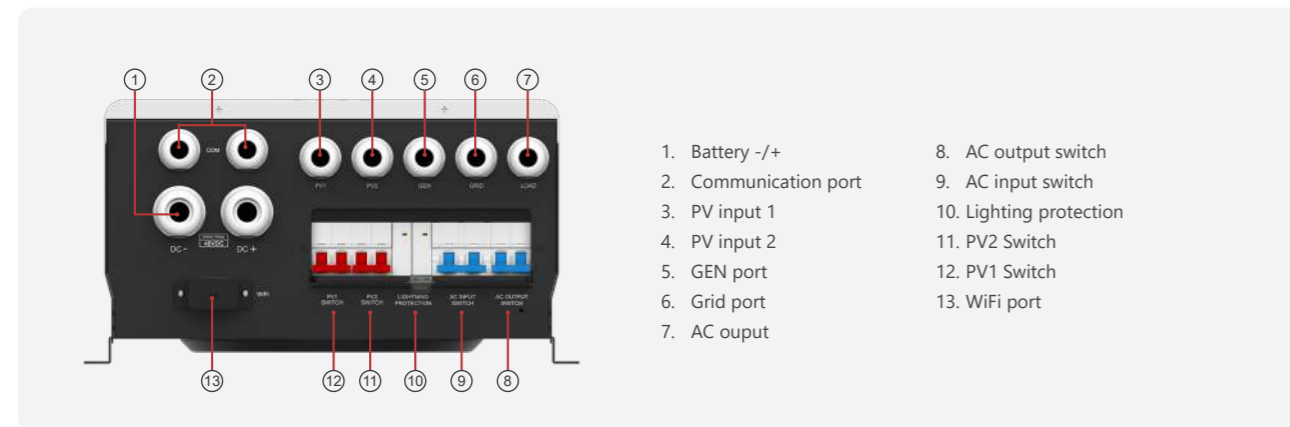

### Parallel operation

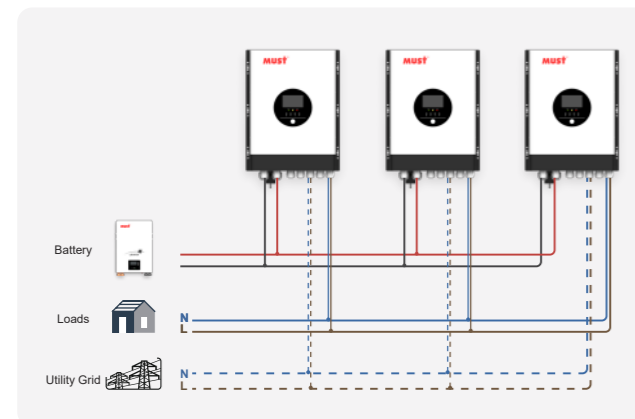

### Solar system connection

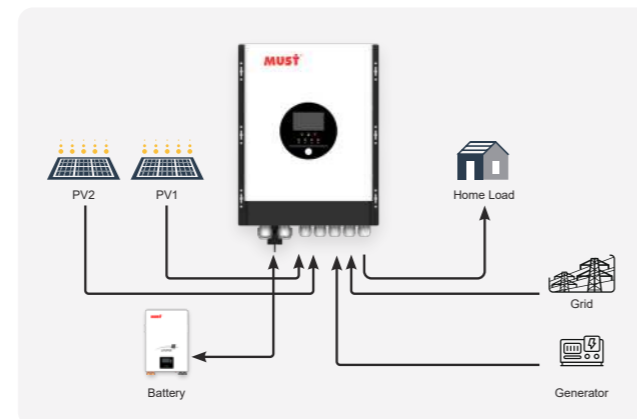

MODEL	PV3900-12048TLV
Nominal Battery System Voltage	48VDC
Stand-alone mode	Yes
Parallel operation	3 units
<b>INVERTER OUTPUT</b>	
Rated power	12.0KW
Surge rating	36000VA
Capable of starting electric motor	6HP
Waveform	Pure sine wave / same as input (bypass mode)
Nominal output voltage RMS	100V/110V/120V/200V/220V/240V
Inverter efficiency(peak)	>90%
Line mode efficiency	>95%
Power factor	1.0
Typical transfer time	20ms(max)
<b>AC INPUT</b>	
Voltage	220V/230V/240V
Selectable voltage range	90-280 VAC (APL)
Frequency range	50Hz / 60Hz
<b>BATTERY</b>	
Low battery voltage cutoff	40-48VDC for 48VDC mode
Low battery voltage recover	42-50VDC for 48VDC mode
High battery voltage cutoff	60VDC for 48VDC mode
High battery voltage recover	57VDC for 48VDC mode
Idle consumption-search mode	<50W
<b>AC CHARGER</b>	
Output voltage	Depends on battery type (Supports lead-acid, gel, and lithium batteries)
Charger AC input breaker rating	100A
Overcharge protection S.D.	62.8VDC for 48VDC mode
Maximum charge current	10-140A (setting) battery terminal
<b>BTS</b>	
Continuous output power	Yes Variances in charging voltage & S.D. voltage base on the battery temperature
<b>BYPASS &amp; PROTECTION</b>	
Input voltage waveform	Sine wave (grid or generator)
Nominal input frequency	50Hz or 60Hz
Overload protection (SMPS Load)	Software + Circuit breaker
Output short circuit protection	Software + Circuit breaker
Bypass breaker rating	63A
Max bypass current	80A
<b>SOLAR CHARGER</b>	
Maximum PV charge current	200A
DC voltage	48V
Maximim PV array power	10000W
MPPT range @ operating voltage(VDC)	64~235VDC
Maximum PV array open circuit voltage	250VDC
Maximum efficiency	>98%
Standby power consumption	<2W
<b>MECHANICAL SPECIFICATIONS</b>	
Mounting	Wall mount
Packing	Wooden box
Dimensions (W*H*D)	439*570*233mm
Package Dimensions (W*H*D)	690*214*520mm
N.W	42kg
G.W	47kg
Warranty	1years
<b>OTHER</b>	
Operation temperature range	0°C to 50°C
Storage temperature	15°C to 60°C
Audible noise	60dB MAX
Communication	WiFi
Display	LED+LCD
<b>CERTIFICATION &amp; STANDARDS</b>	
CE-LVD (IEC62109-1:2010, EN IEC62109-2:2011); UL1741	