



Download
Manual



🔍 Growatt New Energy

Shenzhen Growatt New Energy Co., Ltd.

4-13/F, Building A, Sino-German (Europe) Industrial Park,
Hangcheng Blvd, Bao'an District, Shenzhen, China

E service@growatt.com

W en.growatt.com

For local customer support, please visit <https://en.growatt.com/support/contact>



(PN:044.SK0020700)



PV Off-grid Inverter
SPE 12000 US/SPE 10000 US /
SPE 8000 US/SPE 6000 US
User Manual

About This Document

This document introduces PV Off-grid Inverter SPE 6000-12000 US in terms of its installation, electrical connection, operation, commission, maintenance, and troubleshooting. Before installing and operating Inverter ensure that you are familiar with the product features, functions, and safety precautions provided in this document.

Symbol	Description
 DANGER	Indicates a hazardous situation which, if not avoided, will result in death or serious injury.
 WARNING	Indicates a potentially hazardous situation, if not avoided, could result in serious injury or death.
 NOTICE	Is used to address practices which are not safety relevant.

Change history

Version 1.0

First release

Table of Contents

1 Information on this Manual	1
1.1 Validity	1
1.2 Scope	1
1.3 Target Group	1
1.4 Safety Instructions	1
2 Product Overview	3
2.1 Product Features	3
2.2 Panel and Port Definitions	4
3 Installation Instructions	5
3.1 Accessory list	5
3.2 Points for attention	5
3.3 Battery Connection	6
3.3.1 Wiring preparation	6
3.3.2 Battery power cable connection	8
3.3.3 Lithium battery communication cable connection	8
3.4 AC Connection	9
3.4.1 Connection preparation	9
3.4.2 Grid/GEN/ Load wires Connection	10
3.5 PV Connection	12
3.5.1 Connection preparation	12
3.5.2 PV cable Connection	13
3.6 Communication Connection	13
3.7 Dry Contact Signal	13
3.8 Final Assembly	15
3.9 Wiring system for inverter	15
4 Operations	16
4.1 Power ON/OFF	16
4.2 Display Panel Introduction	16
4.2.1 LCD Display Icons	17
4.2.2 Display Information	19
4.2.3 Operating Mode Description	21
4.3 LCD parameter setting	23
4.3.1 General settings	23
4.3.2 Hide settings	34
5 Parallel Installation Guide	38
5.1 Parallel accessories	38
5.2 Points of Attention for Parallel	38
5.3 Wire Connections	39
5.3.1 Parallel expansion system wire connection	39
5.3.2 Three-phase parallel wire connection	41
5.4 Parallel Example	43
5.5 Parallel setup and display	44
6 Fault Reference Code	46
6.1 Fault Reference Code	46
6.2 Warning Indicator	47
7 Specifications	49
7.1 PV Specification	49
7.2 AC Input Specification	49
7.3 Battery Mode Specification	50
7.4 Smart Load Output Power Specification	50
7.5 Overload Capability Specification	50
7.6 Battery & Charger Specification	51
7.7 General Specification	52
8 Appendix	52
Appendix I Fault information and processing	52
Appendix II Restore factory settings	56
Appendix III Battery Equalization	56
Appendix IV Routine maintenance	58
Appendix V WIFI Monitoring	59

1 Information on this Manual

1.1 Validity

This manual is valid for the following devices:

- SPE 12000 US, SPE 10000 US, SPE 8000 US, SPE 6000 US

1.2 Scope

This manual describes the assembly, installation, operation and troubleshooting of this unit. Please read this manual carefully before installations and operations.

1.3 Target Group

This document is intended for qualified persons and end users. Tasks that do not require any particular qualification can also be performed by end users. Qualified persons must have the following skills:

- Knowledge of how an inverter works and is operated.
- Training in how to deal with the dangers and risks associated with installing and using electrical devices and installations.
- Training in the installation and commissioning of electrical devices and installations.
- Knowledge of the applicable standards and directives.
- Knowledge of and compliance with this document and all safety information.

1.4 Safety Instructions



WARNING

This chapter contains important safety and operating instructions. Read and keep this manual for future reference.

1. Before using the unit, read all instructions and cautionary marking on the unit, the batteries and all appropriate sections of this manual. The company has the right not to quality assurance, if not according to the instructions of this manual for installation and cause equipment damage.
2. All the operation and connection please professional electrical or mechanical engineer.
3. All the electrical installation must comply with the local electrical safety standards.
4. When install PV modules in the daytime, installer should cover the PV modules by opaque materials, otherwise it will be dangerous as high terminal voltage of modules in the sunshine.
5. **CAUTION**-To reduce risk of injury, charge only deep-cycle lead-acid type rechargeable batteries and lithium batteries. Other types of batteries may burst, causing personal injury and damage.
6. Please be clear which kind of battery system you want, lithium battery system or lead-acid battery system, if you choose the wrong system, energy storage system can't work normally.

7. **NEVER** charge a frozen battery.
8. Be very cautious when working with metal tools on or around batteries. A potential risk exists to drop a tool to spark or short circuit batteries or other electrical parts and could cause an explosion.
9. For optimum operation of this inverter, please follow required spec to select appropriate cable size. It's very important to correctly operate this inverter.
10. Please strictly follow installation procedure when you want to disconnect AC or DC terminals. Please refer to INSTALLATION section of this manual for the details.
11. **GROUNDING INSTRUCTIONS** -This inverter should be connected to a permanent grounded wiring system. Be sure to comply with local requirements and regulation to install this inverter.
12. **NEVER** cause AC output and DC input short circuited. Do NOT connect to the mains when DC input short circuits.
13. Make sure the inverter is completely assembled, before the operation.
14. Do not disassemble the unit. Take it to a qualified service center when service or repair is required. Incorrect re-assembly may result in a risk of electric shock or fire.
15. To reduce risk of electric shock, disconnect all wirings before attempting any maintenance or cleaning. Turning off the unit will not reduce this risk.
16. This is a class A product. In a domestic environment this product may cause radio interference in which case the user may be required to take adequate measures.

2. Product Overview

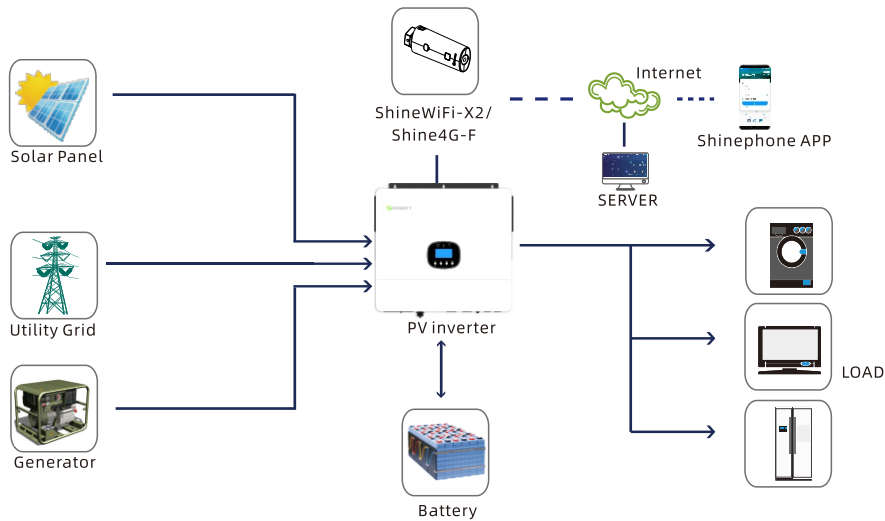

Fig 2.1 Hybrid Power System

This is a multifunctional PV Hybrid inverter, integrated with a MPPT solar charge controller, a high frequency pure sine wave inverter and a UPS function module in one machine, which is perfect for off grid backup power and self-consumption applications. This inverter can work with or without batteries.

The whole system also need other devices to achieve complete running such as PV modules, generator, or utility grid. Please consult with your system integrator for other possible system architectures depending on your requirements. The WIFI / 4G module is a plug-and-play monitoring device to be installed on the inverter. With this device, users can monitor the status of the PV system from the mobile phone or from the website anytime anywhere.

2.1 Product Features

- Rated power 6KW to 12KW, power factor 1.
- 2 strings of MPPT, Max. PV array power 9000watt to 18000Watt.
- MPPT Voltage range 60Vdc-480Vdc, 550Voc.
- Pure sine wave inverter and MPPT solar charge controller integrated inside.
- Built-in ATS for automatic grid and generator switching.
- Able to work with or without battery.
- With CAN/RS485 for BMS communication.
- WIFI/4G wireless monitoring(optional).
- Parallel operation up to 9 units (only with battery connected).
- With smart load function.

2.2 Panel and Port Definitions

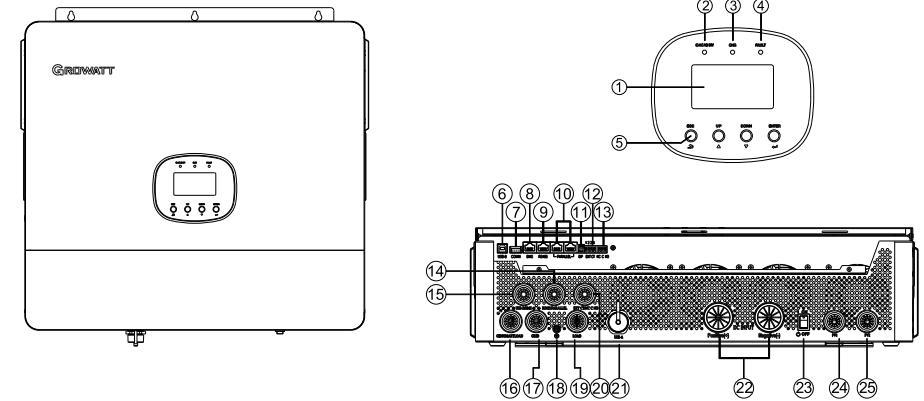

Fig 2.2 Panel and Port Definitions

Panel operation	
1. LCD display	2. Status indicator
3. Charging indicator	4. Fault indicator
5. Function buttons	
Communication port	
6. USB communication port	7. Connection 21
8. BMS communication port (support CAN/RS485)	9. RS485 communication port (for expansion)
10. Parallel communication ports	11. Parallel communication DIP
12. NC	13. Dry contact
21. WIFI / 4G communication port	
Connection port	
16. Generator input(smart load)	17. Grid input
18. PE	19. AC output(main)
22. Battery input	
24. PV1 input	25. PV2 input
Other	
23. Power on/off switch	

3. Installation Instructions

3.1 Accessory list

Part List		
Item	Item Name	Qty.
A	The unit	1
B	Communication cable	1
C	Parallel communication cable	1
D	R-type terminal	1
E	O-type terminal	4
F	User manual	1

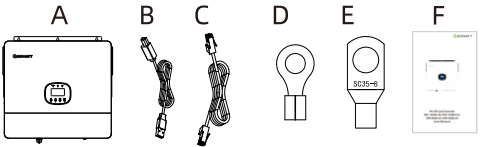

3.2 Points for attention

Consider the following points before selecting where to install:

- Install this inverter at eye level in order to allow the LCD display to be read at all times.
- The ambient temperature should be between -10°C and 50°C to ensure optimal operation.
- The recommended installation position is to be adhered to the wall vertically.
- Do not install in too narrow confined space and pay attention to ventilation.

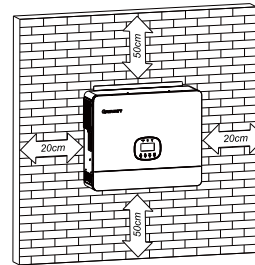

Be sure to keep other objects and surfaces as shown in the right diagram to guarantee sufficient heat dissipation and to have enough space for removing wires.

! If the energy storage is installed in areas with salt damage, it will be corroded and may cause fire.

Therefore, do not install it outdoors in areas with salt damage. The areas with salt damage are defined as the areas which are not 500m away from shore or will be affected by sea breezes. The areas affected by the sea breezes vary depending on meteorological conditions (e.g. typhoons, monsoons) or topographical conditions (dams, hills).

! SUITABLE FOR MOUNTING ON CONCRETE OR OTHER NON-COMBUSTIBLE SURFACE ONLY.

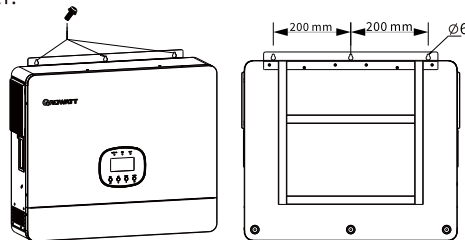

Install the unit by screwing three screws. It's recommended to use M4 or M5 screws.

Preparation for wiring.

Before connecting all wiring, please take off bottom cover by removing four screws as shown below.

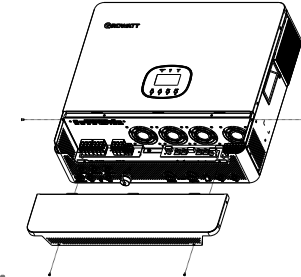

3.3 Battery Connection



WARNING

All wiring must be performed by a qualified person.

- Shock Hazard: Installation must be performed with care due to high battery voltage in series.
- Always disconnect all circuit breakers before making connections to the battery power cable.
- Make sure the battery power cable positive (+) must be connected to battery positive (+), negative (-) must be connected to battery negative (-).
- Do not place anything between the flat part of the inverter terminal and the ring terminal. Otherwise, a short circuit may occur, resulting in overheating and fire.
- Do not apply anti-oxidant substance on the terminals before terminals are connected tightly.

3.3.1 Wiring preparation

1. For safety operation and regulation compliance, it's requested to install a separate DC breaker (over-current protector) or disconnect device between battery and inverter. It may not be requested to have a disconnect device in some applications, however, it's still requested to have DC breaker installed. Please refer to typical amperage in below table as required breaker size.

Recommended DC breaker specification of battery for a single inverter:

Model	1 unit*
SPE 12000 US	400A / 60VDC
SPE 10000 US	350A / 60VDC
SPE 8000 US	300A / 60VDC
SPE 6000 US	200A / 60VDC

2、It's very important for system safety and efficient operation to use appropriate cable for battery connection. To reduce risk of injury, please use the proper recommended cable and terminal size as below.

Recommended battery cable and terminal size:

Model	Wire Size		Torque value
SPE 12000 US	2 * 2 AWG	2*33.62mm ²	2-3 Nm
SPE 10000 US	2 * 2 AWG	2*33.62mm ²	2-3 Nm
SPE 8000 US	2 * 4 AWG	2*21.15mm ²	2-3 Nm
SPE 6000 US	2 * 4 AWG	2*21.15mm ²	2-3 Nm

O-type terminal:

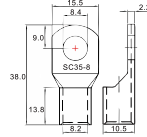

3、 Battery Module Selection: Choose the appropriate battery according to the actual situation.

Battery Type	SPE 12000 US	SPE 10000 US	SPE 8000 US	SPE 6000 US
Lead-acid Battery	400Ah capacity battery	300Ah capacity battery	300Ah capacity battery	200Ah capacity battery
Lithium Battery	400Ah capacity battery	300Ah capacity battery	300Ah capacity battery	200Ah capacity battery

3.3.2 Battery power cable connection

Please follow below steps to implement battery connection:

- 1、 Assemble battery ring terminal based on recommended battery cable and terminal size.
- 2、 Connect all battery packs as units requires.
- 3、 Insert the ring terminal of battery cable flatly into battery connector of inverter and make sure the bolts are tightened with torque of 2Nm.

Make sure polarity at both the battery and the inverter/charge is correctly connected and ring terminals are tightly screwed to the battery terminals.

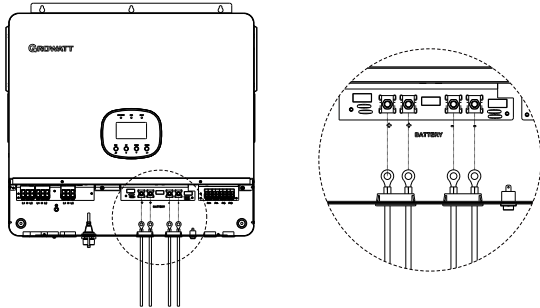

3.3.3 Lithium battery communication cable connection

If used with lithium batteries, make sure to connect the BMS communication cable between the battery and the inverter. It is recommended to use lithium batteries that have been tested with our configuration.

Please follow below steps to implement BMS communication cable connection:

- 1、 Connect one end of the battery's communication cable to the inverter's BMS communication port (below left), which supports RS485 or CAN protocols.

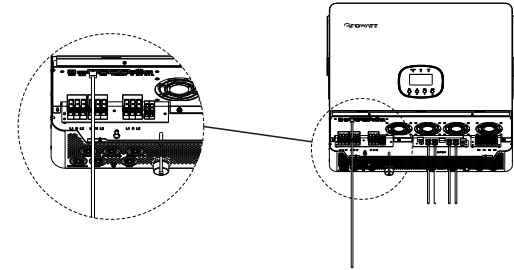

- 2、 The other end of the battery communication cable plugs into the battery communication port (RS485 or CAN).

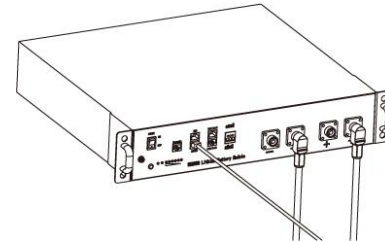

- 3、 The inverter BMS port pin and RS485 port pin assignment shown as below:

Pin number	BMS port	RS485 port (for expansion)
1	RS485B	RS485B
2	RS485A	RS485A
3	--	-
4	CANH	-
5	CANL	-
6	--	-
7	--	-
8	-	-

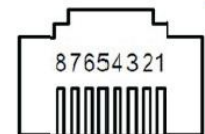

Note: The RS485 port (for expansion) is used for communication expansion and connection to external devices.

Note: In order to ensure the normal communication of lithium battery BMS, please set the battery type as "Li" in program 5, and then LCD will automatically switch to program 36 to select the communication protocol. You can Choose RS485 communication protocol which is from L01 to L50, and you can also choose CAN Communication protocol which is from L51 to L99. (About the specific protocol address of the inverter, please consult the dealer or manufacturer to choose which communication protocol to match the BMS).

3.4 AC Connection



WARNING

- All wiring must be performed by a qualified personnel.
- Shock Hazard: Be sure that AC power source is disconnected before attempting to wire it to the unit.
- Always disconnect all circuit breakers before making Grid/ GEN/ AC output connection.
- Be sure to connect AC wires with correct polarity. If L and N wires are connected reversely, it may cause utility short-circuited when these inverters are worked in parallel operation.
- There are three terminal blocks with "Grid", "GEN/Smart Load" and "Load" markings. Please do not mistakenly connect the input and output connectors.
- Appliances such as air conditioner are required at least 2~3 minutes to restart because it's required to have enough time to balance refrigerant gas inside of circuits. If a power shortage occurs and recovers in a short time, it will cause damage to your connected appliances. To prevent this kind of damage, please check with manufacturer of air conditioner that if it's equipped with time-delay function before installation. Otherwise, this off grid solar inverter will trig overload fault and cut off output to protect your appliance but sometimes it still causes internal damage to the air conditioner.

3.4.1 Connection preparation

1、 Before connecting to AC input power source, please install a separate AC breaker between inverter and Grid power source. This will ensure the inverter can be securely disconnected during maintenance and fully protected from over current of Grid. Please refer to typical amperage in below table as required breaker size.

Recommended breaker specification of Grid for a single inverter:

Model	1 unit*
SPE 12000 US	70A / 230VAC
SPE 10000 US	70A / 230VAC
SPE 8000 US	70A / 230VAC
SPE 6000 US	70A / 230VAC

2. It is very important for system safety and efficient operation to use appropriate cable for Grid connection , GEN connection, Load connection and Smart Load connection. To reduce risk of injury, please use the proper recommended cable size as below.

Recommended AC wires size:

Model	AC Input Wire Size		AC Output Wire Size		Torque value
SPE 12000 US	1 * 6 AWG	13.3mm ²	1 * 6 AWG	13.3mm ²	1.2-1.6 Nm
SPE 10000 US	1 * 6 AWG	13.3mm ²	1 * 7 AWG	10.55mm ²	1.2-1.6 Nm
SPE 8000 US	1 * 6 AWG	13.3mm ²	1 * 8 AWG	8.37mm ²	1.2-1.6 Nm
SPE 6000 US	1 * 6 AWG	13.3mm ²	1 * 8 AWG	8.37mm ²	1.2-1.6 Nm

3.4.2 Grid/GEN/ Load wires Connection:

Please follow the steps below to make Load/ Smart Load/ Grid/ GEN connections:

1. Remove the insulation covers of the seven wires.
2. Connect the PE protection line first, and then lock in the Load, Smart Load line, Grid line, and GEN line in order.
3. Corresponding polarity positions marked on the terminals.

Please refer to the following:

 → Ground (yellow- green), L1→LINE (brown or black), N→ Neutral (blue), L2→LINE (grey)

1.Insert first Load wires according to polarities indicated on terminal block and ensure that the buckle presses the wire tightly.

L1→ LINE (brown or black), N→ Neutral (blue), L2→LINE (grey)

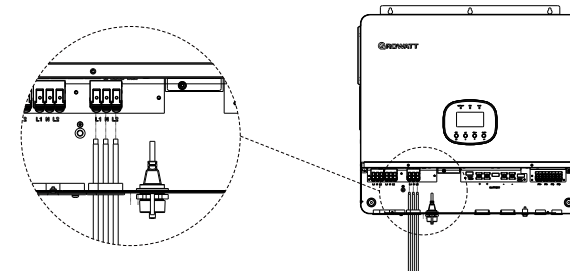

2. Insert Grid wires according to polarities indicated on terminal block and ensure that the buckle presses the wire tightly.

L → LINE (brown or black), N → Neutral (blue), L2 → LINE (grey)

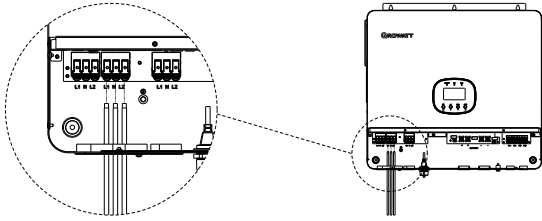

3. Insert GEN or SMARTLOAD wires according to polarities indicated on terminal block and ensure that the buckle presses the wire tightly.

(Refer to Program 90 for how to use them as generator input or smart output.)

L → LINE (brown or black), N → Neutral (blue), L2 → LINE (grey)

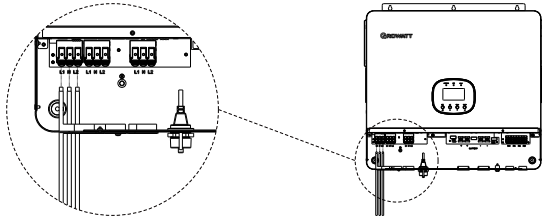

4. Make sure the inverter metal housing is grounded (Ground in the grid system).

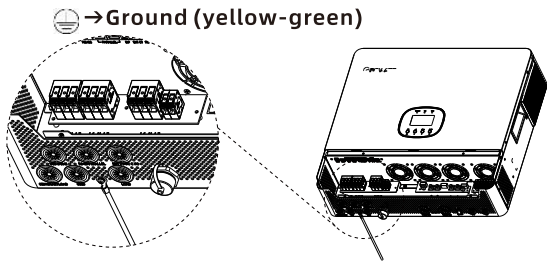

R-type terminal:

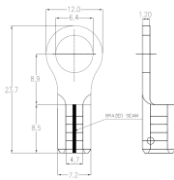

Precautions:

- 1) Before performing the above operations, please ensure that your operating environment is: Non-energized environment.
- 2) After inserting the wire according to the polarity marked on the terminal, don't forget to check that the screw is tightened or the buckle presses the wire tightly.
- 3) After you complete all wiring, please check again to confirm whether the corresponding wires are connected in the correct position to avoid misoperation that may cause the inverter to fail to work properly or damage your equipment. These details that cannot be ignored ensure a good user experience to a certain extent.

3.5 PV Connection



- All wiring must be performed by a qualified personnel.
- Shock Hazard: Operation with power on is strictly prohibited.
- Before connecting the PV input, be sure to turn off all circuit breakers and confirm that the machine is powered off.
- Be sure to connect PV cable with correct polarity.

3.5.1 Connection preparation

1. Before connecting to PV modules, please install separately a DC circuitbreaker between inverter and PV modules.

Recommended breaker specification of PV input for a single inverter:

Model	1 unit*
SPE 12000 US	30A / 550Vdc
SPE 10000 US	30A / 550Vdc
SPE 8000 US	30A / 550Vdc
SPE 6000 US	30A / 550Vdc

2. It's very important for system safety and efficient operation to use appropriate cable for PV module connection. To reduce risk of injury, please use the proper recommended cable size as below

Model	Wire Size		Torque value
SPE 12000 US	1 * 9 AWG	8.4mm ²	1.2-1.6 Nm
SPE 10000 US	1 * 9 AWG	8.4mm ²	1.2-1.6 Nm
SPE 8000 US	1 * 9 AWG	8.4mm ²	1.2-1.6 Nm
SPE 6000 US	1 * 9 AWG	8.4mm ²	1.2-1.6 Nm

3. PV Module Selection:

When selecting proper PV modules, please be sure to consider below parameters:

1. Open circuit Voltage (Voc) of PV modules not exceeds max. PV array open circuit voltage of inverter. Exceeding the limit will cause damage to the inverter.
2. Open circuit Voltage (Voc) of PV modules should be higher than start-up voltage. Lower than will lead to insufficient photovoltaic.

INVERTER MODEL	SPE 12000 US	SPE 10000 US	SPE 8000 US	SPE 6000 US
Max. PV Array Open Circuit Voltage	550Vdc			
Start-up Voltage	120Vdc			
PV Array MPPT Voltage Range	60Vdc~480Vdc (Recommend 380Vdc)			
Quantity Of PV Panels	Recommend 2~11 photovoltaic panels			

3.5.2 PV cable Connection:

Please follow below steps to implement PV module connection:

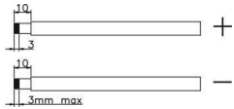

1. Remove insulation sleeve 10 mm for positive and negative conductors.
2. then connect positive pole (+) of connection cable to positive pole (+) of PV input connector, connect negative pole (-) of connection cable to negative pole (-) of PV input connector.

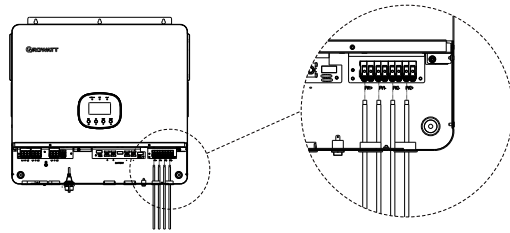

3.6 Communication Connection

Please use supplied communication cable to connect to inverter and PC. Follow on-screen instruction to install the monitoring software. For the detailed software operation, please check user manual of software. The monitoring software is downloadable from our website www.ginverter.com.

3.7 Dry Contact Signal

There is one dry contact(3A/250VAC) available on the rear panel. Dry contacts are used to connect generators. As shown in the table below. When the inverter meets the conditions on the left, it will perform the function on the right. It could be used to deliver signal to external device When the following conditions are met.

Unit Status	Condition	Dry contact port:			
		NC & C	NO & C		
If program 24 is set to automatic					
Power Off	Unit is off and no output is powered	Close	Open		
Power On	Output is powered from Utility	Program 01 set as Utility first	Battery voltage (SOC) < Low DC warning voltage(SOC)	Open	Close
			Battery voltage(SOC) > Setting value in Program 13 or battery charging reaches floating stage	Close	Open
	Output is powered from Battery or Solar	Program 01 is set as SBU or Solar first	Battery voltage (SOC) < Setting value in Program 12	Open	Close
			Battery voltage (SOC) > Setting value in Program 13 or battery charging reaches floating stage	Close	Open
If program 24 is set to enable					
Power On	Output is powered from Battery or Solar	The dry contact always sends a power-on signal.	Open	Close	
If program 24 is set to disable					
Power On	Output is powered from Battery or Solar	The dry contact always sends a power-off signal.	Close	Open	

3.8 Final Assembly

Double check that all wiring is correct. Please put bottom cover back by screwing four screws as shown below.

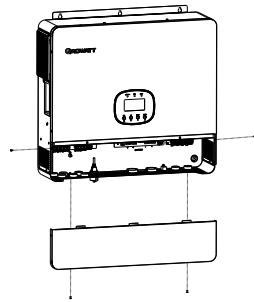

3.9 Wiring system for inverter

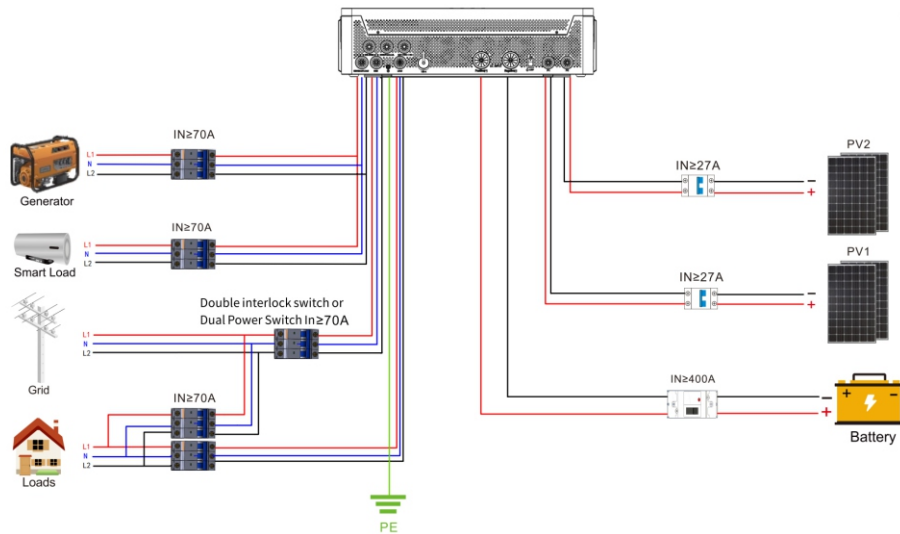

4. Operation

4.1 Power ON/OFF

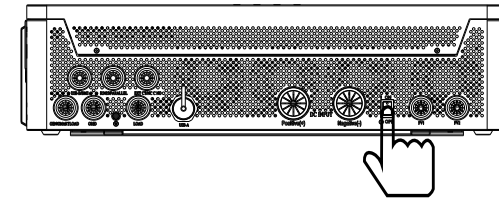

After correct installation, switch on the battery switch, switch on the inverter switch, wait about 40 seconds, inverter output.

4.2 Display Panel Introduction

The operation and display panel, shown in below chart, is on the front panel of the inverter. It includes three indicators, four function keys and a LCD display, indicating the operating status and input/output power information.

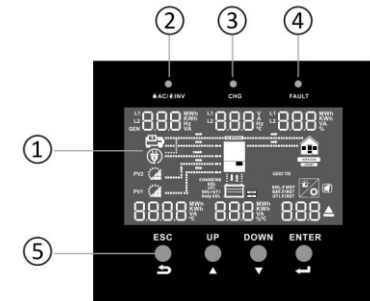

1. LCD display
2. Status indicator
3. Charging indicator
4. Fault indicator
5. Function buttons

LCD display

LED Indicator		Messages	
AC/INV	Green	Solid On	Output is powered by utility in Line mode.
		Flashing	Output is powered by battery or PV in battery mode.
CHG	Green	Solid On	Battery is fully charged.
		Flashing	Battery is charging.
FAULT	Red	Solid On	Fault occurs in the inverter.
		Flashing	Warning condition occurs in the inverter.

Function Buttons

Button	Description
ESC	To exit setting mode
UP	To go to previous selection
DOWN	To go to next selection
ENTER	To confirm the selection in setting mode or enter setting mode

4.2.1 LCD Display Icons

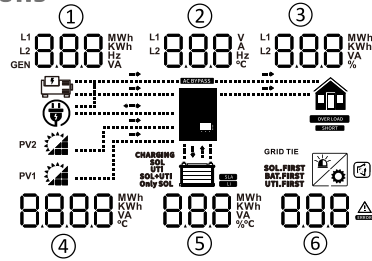

Icon	Description
AC Input Information	
	Grid icon
	Generator icon
①	Indicate AC input power, AC input voltage, AC input frequency, AC input current
	Indicate AC power loads in bypass
PV Input Information	
	Left: PV1 input icon Right: PV2 input icon
④	Indicate PV power, PV voltage, PV current, etc.
Output Information	
	Inverter icon
②	Indicate output voltage, output current, output frequency, inverter temperature
Load Information	
	Load icon
③	Indicate power of load, power percentage of load
	Indicate overload happened
	Indicate short circuit happened
Battery Information	
	Indicate battery level by 0-24%, 25-49%, 50-74% and 75-100% in battery mode and charging status in line mode.
⑤	Indicate battery voltage, battery percentage, battery current
	Indicate SLA battery
	Indicate lithium battery
	Indicate charging source priority: solar first, solar and utility, or only solar
Other Information	
	Indicate output source priority: solar first, utility first, SBU mode or SUB mode

⑥	Indicate warning code or fault code
	Indicate a warning or a fault is happening
	Indicate it's during setting values
	Indicate the alarm is disabled

In battery charge mode, battery icon will present Battery Charging Status		
Status	Battery voltage	LCD Display
Constant Current mode / Constant Voltage mode	<48V	4 bars will flash in turns.
	48 ~ 50V	Bottom bar will be on and the other three bars will flash in turns.
	50 ~ 52V	Bottom two bars will be on and the other two bars will flash in turns.
	> 52V	Bottom three bars will be on and the top bar will flash.
Floating mode. Batteries are fully charged.		4 bars will be on.

In battery discharge mode, battery icon will present Battery Capacity		
Load Percentage	Battery Voltage	LCD Display
Load >50%	< 41.2V	
	41.2~43.2V	
	43.2~45.2V	
	> 45.2V	
50%> Load > 20%	< 43.6V	
	43.6~46V	
	46~47.6V	
	> 47.6V	
Load < 20%	< 44.8V	
	44.8~46.8V	
	46.8~48.8V	
	> 48.8	

4.2.2 Display Information

The LCD display information will be switched in turns by pressing "UP" or "DOWN" key. The selectable information is switched as below order: voltage, frequency, current, power, temperature, energy, firmware version.

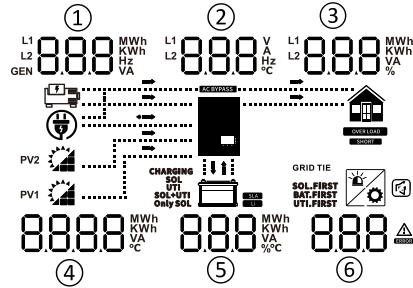

Setting Information	LCD display	
① AC Input voltage Left: Grid Input Phase voltage Right: Grid input Line voltage ② Output voltage ③ Load percentage ④ Left: PV1 input voltage Right: PV2 input voltage ⑤ Battery voltage ⑥ Warning or Fault code *Default Display Screen		
① AC Input voltage Left: Generator Input Phase voltage Right: Generator input Line voltage (If the AC input is only generator input, it means that what is displayed at this time is the input voltage of the generator. The current, power and frequency displayed after turning the page are also the input parameters of the generator, which will not be explained below.) ② Output voltage ③ Load percentage ④ Left: PV1 input voltage		

Right: PV2 input voltage ⑤ Battery voltage ⑥ Warning or Fault code		
① AC Input frequency ② Output frequency ③ Load power ④ PV energy sum ⑤ Battery percentage ⑥ Warning or Fault code		
① AC input power ② Output voltage ③ Load power ④ Left: PV1 input power Right: PV2 input power ⑤ Battery charging power ⑥ Warning or Fault code		
① AC input power ② Inverter temperature ③ Load power ④ Left: PV1 temperature Right: PV2 temperature ⑤ Left: LLC temperature Right: Battery temperature ⑥ Warning or Fault code		
① Left: Today's AC input energy Right: Total AC input energy ② Output frequency ③ Left: Today's load energy Right: Total load energy ④ Left: Today's PV energy Right: Total PV energy ⑤ Left: Today's battery discharge energy Right: Total battery discharge energy ⑥ Indicate today's energy or total energy.		

Firmware version (CPU1:169-00-527; CPU2:142-00-529; CPU3:170-00-528)		
Time (13:54:29, May 29, 2024)		/

4.2.3 Operating Mode Description



Operation mode	Description	LCD display	
Standby mode /Power saving mode Note: *Standby mode: The inverter is not turned on yet but at this time, the inverter can charge battery without AC output. *Power saving mode: If enabled, the output of inverter will be off when connected load is pretty low or not detected.	No output is supplied by the unit but it still can charge batteries.	Charging by PV energy 	No charging
Fault mode Note: *Fault mode: Errors are caused by inside circuit error or external reasons such as over temperature, output short circuited and so on.	PV energy can charge batteries.	Charging by PV energy 	No charging



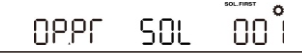

Line Mode	The unit will provide output power from the mains. It can also charge the battery at line mode.	Charging by PV energy
		Charging by utility
		No battery connected
Battery Mode	The unit will provide output power from battery and PV power.	Power from battery and PV energy
		Power from battery only

4.3 LCD parameter setting

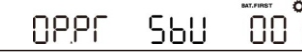
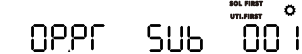
4.3.1 General settings

After pressing and holding ENTER button for 3 seconds, the unit will enter setting mode. Press “UP” or “DOWN” button to select setting programs. Then press “ENTER” button to confirm the selection or ESC button to exit.

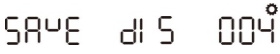
Program	Description	Setting Option
01	Output source priority: To configure load power source priority. (After program 67 are enabled, this program is fixed SUB and cannot be set.)	Solar first 
		Solar energy provides power to the loads as first priority. If solar energy is not sufficient to power all connected loads, battery energy will supply power the loads at the same time. Utility provides power to the loads only when any one condition happens: - Solar energy is not available - Battery voltage drops to either low-level warning voltage or the setting point in program 12.
		Utility first 
		Utility will provide power to the loads as first priority. Solar and battery energy will provide power to the loads only when utility power is not available.
		SBU priority(default) 
		Solar energy provides power to the loads as first priority. If solar energy is not sufficient to power all connected loads, battery will supply power to the loads at the same time. Utility provides power to the loads only when battery voltage drops to either low-level warning voltage or the setting point in program 12.
		SUB priority 
		Solar energy provides power to the loads as first priority. If solar energy is not sufficient to power all connected loads, solar and utility will power loads at the same time. Battery provides power to the loads only when solar energy is not sufficient and there is no utility.

02	Maximum charging current: set total charging current for solar and utility chargers.	 <p>SPE 12000 US: Default 120A, 0A~250A Settable. SPE 10000 US: Default 120A, 0A~220A Settable. SPE 8000 US: Default 120A, 0A~190A Settable. SPE 6000 US: Default 120A, 0A~140A Settable. (Max. charging current = utility charging current + solar charging current) (If LI is selected in Program 5, this program can't be set up)</p>																		
03	AC input voltage range (After program 67 are enabled, this program is fixed UPS and cannot be set).	Appliance (default)  <p>If selected, acceptable AC input voltage range will be within: 65~140VAC</p>																		
		UPS  <p>If selected, acceptable AC input voltage range will be within: 95~140VAC</p>																		
04	Power saving mode enable/disable	Saving mode disable (default)  <p>If disabled, no matter connected load is low or high, the on/off status of inverter output will not be effected.</p>																		
		Saving mode enable  <p>If enabled, the output of inverter will be off when connected load is pretty low or not detected.</p>																		
05	Battery type	AGM (default) – Suitable for lead-acid battery 																		
		<table border="1"> <thead> <tr> <th>Items that cannot be set</th> <th>19</th> <th>20</th> <th>21</th> </tr> </thead> <tbody> <tr> <td>default</td> <td>56.4V</td> <td>54V</td> <td>42V</td> </tr> </tbody> </table>	Items that cannot be set	19	20	21	default	56.4V	54V	42V										
		Items that cannot be set	19	20	21															
default	56.4V	54V	42V																	
<table border="1"> <thead> <tr> <th>Items that can be set:</th> <th>default</th> <th>Set range</th> <th>Set requirements</th> </tr> </thead> <tbody> <tr> <td>02</td> <td>120A</td> <td>0A~250A</td> <td></td> </tr> <tr> <td>11</td> <td>60A</td> <td>0A~250A</td> <td></td> </tr> <tr> <td>12</td> <td>46V</td> <td>44~51.2V</td> <td><13 setting value</td> </tr> <tr> <td>13</td> <td>54v</td> <td>48~58.0V</td> <td></td> </tr> </tbody> </table>	Items that can be set:	default	Set range	Set requirements	02	120A	0A~250A		11	60A	0A~250A		12	46V	44~51.2V	<13 setting value	13	54v	48~58.0V	
Items that can be set:	default	Set range	Set requirements																	
02	120A	0A~250A																		
11	60A	0A~250A																		
12	46V	44~51.2V	<13 setting value																	
13	54v	48~58.0V																		

Flooded–Suitable for lead-acid battery or flood battery

bAtt FLd 005°

Items that cannot be set:	19	20	21
default	58.4V	56V	42V

Items that can be set:	default	Set range	Set requirements
02	120A	0A~250A	
11	60A	0A~250A	
12	48V	44~51.2V	<13 setting value
13	56v	48~58.0V	

Lithium (only suitable when communicated with BMS communication)

bAtt LI 005°

Items that cannot be set:	02	19	20
---------------------------	----	----	----

Items that can be set:	default	Set range	Set requirements
11	20A	0A~250A	
12	50%	10%~95%	<13 setting value
13	95%	15%~100%	
21	20%	5%~50%	<12 setting value

User-Defined–Suitable for lead-acid battery, battery parameters can be set manually

bAtt USE 005°

Items that can be set:	default	Set range	Set requirements
02	120A	0A~250A	
11	60A	0A~250A	
12	46V	44~51.2V	<13 setting value
13	54V	48~58.0V	
19	56.4V	48~58.4V	
20	54V	48~58.4V	
21	42V	40~48V	<12 setting value

User-Defined 2 (suitable when lithium battery without BMS communication or communication protocol not matched with the inverter, battery parameters can be set manually)

bAtt US2 005°

Items that can be set:	default	Set range	Set requirements
02	20A	0A~250A	

11	20A	0A~250A	
12	48V	44~51.2V	<13 setting value
13	52V	48~58.0V	
19	54V	48~58.4V	
20	54V	48~58.4V	Suggestion=19 setting value
21	46V	40~48V	<12 setting value

06	Auto restart when overload occurs	Restart disable (default) LdRS dI S 006°	Restart enable LdRS ENA 006°
07	Auto restart when over temperature occurs	Restart disable (default) tRS dI S 007°	Restart enable tRS ENA 007°
08	Output voltage	120V (default) OUTV 120 008° 100V OUTV 100 008°	110V OUTV 110 008°
09	Output frequency	50Hz OUTF 50 009°	60Hz (default) OUTF 60 009°
11	Maximum utility & Generator charging current	ACI 60^ GENI 40^ 011° SPE 12000 US: Default 60A/40A, 0A~250A Settable. SPE 10000 US: Default 60A/40A, 0A~220A Settable. SPE 8000 US: Default 60A/40A, 0A~190A Settable. SPE 6000 US: Default 60A/40A, 0A~140A Settable. Note: If setting value in Program 02 is smaller than that in Program 11, the inverter will apply charging current from Program 02 for utility charger	
12	Setting voltage point back to utility source when selecting "SBU priority" or "Solar first" in program 01	b2AC 460° 012° The default value and adjustable range vary in different Battery type, please refer to program 5 for details	

13	Setting voltage point back to battery mode when selecting "SBU priority" or "Solar first" in program 01 or "Solar first" in program 01	AC26 540° 013° The default value and adjustable range vary in different Battery type, please refer to program 5 for details	
14	Charger source priority: To configure charger source priority.	If this off grid solar inverter is working in Line, Standby or Fault mode, charger source can be programmed as below:	
		Solar first (default) CGPF SOL 014°	Solar energy will charge battery as first priority. Utility will charge battery only when solar energy is not available.
		Solar and Utility CGPF SNU 014°	Solar energy and utility will both charge battery.
		Only Solar CGPF ONLY SOL 014°	Solar energy will be the only charger source no matter utility is available or not.
If this PV Hybrid Inverter is working in Battery mode or Power saving mode, only solar energy can charge battery. Solar energy will charge battery if it's available and sufficient.			
15	Alarm control	Alarm on (default) BUZZ ON 015°	Alarm off BUZZ OFF 015°
16	Backlight control	Backlight on LEDdb ON 016°	Backlight off (default) LEDdb OFF 016°
17	Beeps while primary source is interrupted	Alarm on (default) ALAr ON 017°	Alarm off ALAr OFF 017°
18	Overload bypass: When enabled, the unit will transfer to line mode if overload occurs in battery mode.	Bypass disable (default) byp dis 018°	Bypass enable byp ENA 018°
		C.V. charging voltage. CV 56.4° 019° Default 56.4V, 48.0V~58.4V Settable	

20	Floating charging voltage.	FLEV 540° 020° Default 54.0V, 48.0V~58.4V Settable	
21	Low DC cut-off voltage.	CLEV 420° 021° The default value and adjustable range vary in different Battery type, please refer to program 5 for details Note: The low voltage alarm point is (program 21) +2V. When this value is reached, the machine reports 04. When reach Low DC cut-off voltage: 1) If battery power is only power source available, inverter will shut down. 2) If PV energy and battery power are available, inverter will charge battery without AC output. If PV energy, battery power and utility are all available, inverter will transfer to line mode and provide output power to loads, and charge the battery at the same time.	
		Parallel expansion: (default) ANG 180	Three-phase parallel operation: L1 is set as R-phase and L2 is set as S-phase PFL P12 023°
23	AC output mode *This setting is only available when the inverter is in standby mode (Switch off). Note: Parallel operation can only work when battery connected	Three-phase parallel operation: L1 is set as S-phase and L2 is set as T-phase PFL P23 023°	Three-phase parallel operation: L1 is set as T-phase and L2 is set as R-phase PFL P31 023°
		When the units are paralleled for expansion or used alone, please select "PLV" in program 23. When the two-phase phase angle is 180 degrees, please select 180; when the phase angle is 120 degrees, please select 120. At least two or more inverters are required to support three-phase equipment, and 1 inverter has two phases. Please select "P12" in program 23 to connect to R-phases and S-phases, "P23" to connect to S-phases and T-phases, and "P31" to connect to T-phases and R-phases.	

24	Dry Contact Signal For details, please refer to Chapter 3.7	Automatic (default) dry Ato 024 ^o	The dry contact can intelligently generate a power-on or power-off signal to the generator based on the battery voltage.
		Enable dry ENA 024 ^o	The dry contact always sends a power-on signal.
		Disable dry diS 024 ^o	The dry contacts always send a power-off signals.
28	Address setting (for expansion)	Addr 1 028 ^o Default 1, 1~255 Settable	
36	RS485 Communication protocol	PtCL L01 036 ^o	Protocol 1~50
	CAN Communication protocol	PtCL L51 036 ^o	Protocol 51~99
37	Real time setting---Year	2018 037 ^o	Default 2018, range 2018~2099
38	Real time setting---Month	12 038 ^o	Default 01, range 01~12
39	Real time setting---Date	13 039 ^o	Default 01, range 01~31
40	Real time setting---Hour	13 040 ^o	Default 00, range 00~23
41	Real time setting---Minute	50 041 ^o	Default 00, range 00~59
42	Real time setting---Second	50 042 ^o	Default 00, range 00~59
43	Battery equalization	Battery equalization enable E9 ENA 043 ^o	Battery equalization disable(default) E9 diS 043 ^o
		If "Flooded" or "User-Defined" is selected in program 05, this program can be set up.	

44	Battery equalization voltage	Default 58.4V, 48.0V~58.4V Settable E9 58.4 044 ^o	
45	Battery equalized time	71 0 E9 60 045 ^o	Default 60min, 5min~900min Settable
46	Battery equalized timeout	71 0 E9 120 046 ^o	Default 120min, 5min~900min Settable
47	Equalization interval	dry 30 047 ^o	Default 30days, 1 days~90 days Settable
48	Equalization activated immediately	Equalization activated immediately on E9 ON 048 ^o	Equalization activated immediately off(default) E9 OFF 048 ^o
		If equalization function is enabled in program 43, this program can be setup. If "On" is selected in this program, it's to activate battery equalization immediately and LCD main page will shows "E9". If "Off" is selected, it will cancel equalization function until next activated equalization time arrives based on program 47setting. At this time, "E9" will not be shown in LCD main page.	

49	Utility charging time	0000(default) Allow utility to charge the battery all day run. CHG 017 0000 049	The time allows utility to charge the battery. Use 4 digits to represent the time period, the upper two digits represent the time when utility start to charge the battery, setting range from 00 to 23, and the lower two digits represent the time when utility end to charge the battery, setting range from 00 to 23. (eg: 2320 represents the time allows utility to charge the battery is from 23:00 to the next day 20:59, and the utility charging is prohibited outside of this period)
50	Utility output time	0000(default) Allow utility to power the load all day run. OUP 017 0000 050	The time allows utility to power the load. Use 4 digits to represent the time period, the upper two digits represent the time when utility start to power the load, setting range from 00 to 23, and the lower two digits represent the time when utility end to power the load, setting range from 00 to 23. (eg: 2320 represents the time allows utility to power the load is from 23:00 to the next day 20:59, and the utility power is prohibited outside of this period)
54	Lithium battery strong charging execution cycle time. (If program 05 is set to Li and set to ON, it means that the lithium battery is periodically forced to charge to SOC of 100%. OFF indicates that the function is not enabled)	OFF: Turn off periodic strong charging L11 OFF 054	ON: Turn on periodic strong charging. Default 30days, 1 days~90 days Settable L11 ON 054 L11 030 054

55	Setting solar energy supply priority when selecting "SUB priority" in program 01	Charge first S07d 6LU 055	Solar energy provides power to charge battery as first priority. Solar energy provides power to the loads as second priority. Solar energy provides power to feed to grid as third priority.
		Load first(default) S07d 6LU 055	Solar energy provides power to the loads as first priority. Solar energy provides power to the charge battery as second priority. Solar energy provides power to feed to grid as third priority.
56	NG relay enable setting	NG relay enable(default) NGRY ENA 056	Grounding in inverter operation mode, ungrounded in grid operation mode
		NG relay disable NGRY DIS 056	No grounding in any mode
57	The power grid mode allows the smart load output to remain on.	Disable(default) OP2 DIS 057	Enable OP2 ENA 057
58	Setting of the smart load output time period. * Note: When time period 1 is set to "Sta0000-End0000", it means that the smart load can output all time periods.	First time period 0000 001 058	Smart load output start time 0000 StA 058
			Smart load output shutdown time 0000 ENd 058
		Second time period 0000 002 058	Smart load output start time 0000 StA 058
			Smart load output shutdown time 0000 ENd 058
		Third time period 0000 003 058	Smart load output start time 0000 StA 058
			Smart load output shutdown time 0000 ENd 058
The time setting consists of 4 digits, with the first two digits representing hours and the last two digits representing minutes. For example, Sta2300-End2059 represents the smart load output time range from 23:00 to 20:59 the next day.			

59	The cut-off battery voltage point/SOC setting for the smart load output.	LOSS 480 ^v 059 ^o Default 48.0V, 44.0V~54.0V Settable Lithium battery mode: Default 60%, 20%~95% Settable
60	Recovery battery voltage point/SOC setting for the smart load output.	BRCT 530 ^v 060 ^o Default 53.0V, 48.0V~58.0V Settable Lithium battery mode: Default 90%, 20%~100% Settable
61	Setting of PV power value for the smart load output to be turned on	PVL 00 ^{KW} 061 ^o SPE 12000 US: Default 0KW, 0KW~12KW Settable SPE 10000 US: Default 0KW, 0KW~10KW Settable SPE 8000 US: Default 0KW, 0KW~8KW Settable SPE 6000 US: Default 0KW, 0KW~6KW Settable
62	Menu Return Settings	Disable(default) MENU DIS 062 ^o Display screen page remains stuck
		Enable MENU ENA 062 ^o Automatically return to the main page after no human-machine interface operation within five minutes
65	Generator run time	GEN RUN 01 0 HOUR 00 065 ^o Default 00, range 01~24 The time allows Generator to work. Use 2 digits to represent the time period, setting range from 00 to 24. (eg: 02 represents the time allows Generator to run for two hours. Note: 00 represents that the generator can run continuously.
66	BMS Communication Loss	Enable (default) BUSE ENA 066 ^o If BMS Communication Loss, The inverter 04 and 20 warning Icon flashing, but enable to work for original status.
		Disable BUSE DIS 066 ^o If BMS Communication Loss, The inverter 04 and 20 warning Icon flashing and disable to work.(cut off the output and can't charge)

90	GEN/SMARTLOAD port can be used as generator input or smart load output.	STAP GEN 090 ^o	GEN/SMARTLOAD Port as generator input (default)
		STAP OP2 090 ^o	GEN/SMARTLOAD Port as smart load output

4.3.2Hide settings

1) After pressing and holding UP and DOWN buttons at the same time for 3 seconds, the unit will enter PASS mode. Change the middle three numbers 000 to 111.

Program	Description	Setting Option	
27	Inverter model query (View the inverter model size of the current model.)	HCRP 120 027 ^o	SPE 12000 US: The model of the current model is 12.0KW.
		HCRP 100 027 ^o	SPE 10000 US: The model of the current model is 10.0KW.
		HCRP 080 027 ^o	SPE 8000 US: The model of the current model is 8.0KW.
		HCRP 060 027 ^o	SPE 6000 US: The model of the current model is 6.0KW.
29	Grid input voltage (L1-L2) calibration	224 ^v GridV 224 ^v 029 ^o	Users can calibrate the grid voltage within a range of ± 9V based on the current grid voltage parameters displayed in the upper left corner of the LCD screen. Calibrate the grid voltage by inputting the actual grid voltage. *Note: The grid voltage must be greater than 90V for voltage calibration
	Grid input voltage (L1-N) calibration	125 ^v Grid1 125 ^v 029 ^o	
	Grid input voltage (L2-N) calibration	125 ^v Grid2 125 ^v 029 ^o	

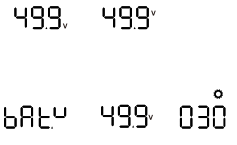
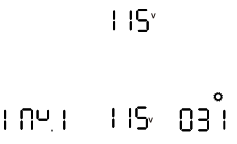
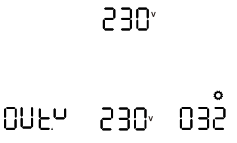
30	Battery voltage calibration		<p>Users can calibrate the battery voltage within a range of $\pm 9V$ based on the current battery voltage parameters displayed in the upper left corner of the LCD screen. Calibrate the battery voltage by inputting the actual battery voltage.</p> <p>* Note: The battery voltage must be greater than 40V for voltage calibration.</p>
31	Inverter voltage calibration		<p>Users can calibrate the inverter voltage within a range of $\pm 9V$ based on the current inverter voltage parameters displayed on the LCD screen. Input half of the true inverter voltage to complete the calibration.</p> <p>*Note: The inverter voltage must be greater than 90V for voltage calibration</p> <p>*Note: The lower left corner icon INV.1 represents the calibration of the L1-N inverter voltage, and INV.2 represents the L2-N inverter voltage.</p>
32	AC output voltage calibration		<p>Users can calibrate the output voltage within a range of $\pm 9V$ based on the current AC output voltage parameters displayed on the LCD screen. Calibrate the AC output voltage by inputting the actual AC output voltage.</p> <p>Note: AC output voltage must be greater than 90V to perform voltage calibration</p> <p>Note: The lower left corner icon OUT.V represents the calibrated L1-L2 output voltage, OUT.1 represents the calibrated L1-N output voltage, and OUT.2 represents the L2-N output voltage</p>

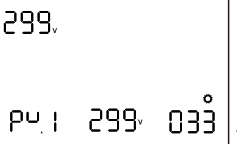
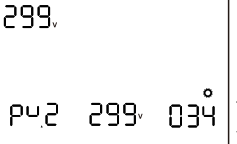
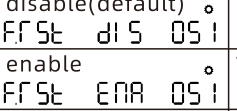
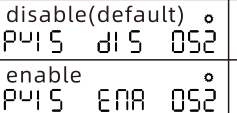
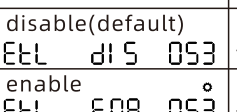
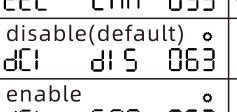
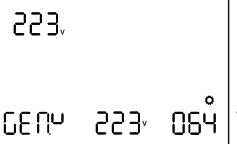
33	PV1 voltage calibration		<p>Users can perform PV1 voltage calibration within a range of $\pm 9V$ based on the current PV1 voltage parameters displayed in the upper left corner of the LCD screen. Enter the real PV1 voltage to calibrate the voltage of PV1.</p> <p>Note: PV1 voltage must be greater than 150V for voltage calibration</p>
34	PV2 voltage calibration		<p>Users can perform PV2 voltage calibration within a range of $\pm 9V$ based on the current PV2 voltage parameters displayed in the upper left corner of the LCD screen. Enter the real PV2 voltage to calibrate the voltage of PV2.</p> <p>Note: PV2 voltage must be greater than 150V for voltage calibration</p>
51	Fault restart		<p>The inverter cannot automatically restart after reporting a fault.</p> <p>The inverter can automatically restart after reporting a fault.</p>
52	PV ISO detection		<p>Disable PV ISO detection function.</p> <p>Enable PV ISO detection function.</p>
53	Redundant relay detection		<p>Disable redundant relay detection function.</p> <p>Enable redundant relay detection function.</p>
63	Inverter current DC component protection		<p>Disable inverter current DC component protection function.</p> <p>Enable inverter current DC component protection function.</p>
64	Generator input voltage calibration		<p>Users can calibrate the generator voltage within a range of $\pm 9V$ based on the current generator voltage parameters displayed in the upper left corner of the LCD screen. Enter the real generator voltage to calibrate the voltage of generator</p> <p>*Note: The generator voltage must be greater than 90V for voltage calibration.</p>

81	GFCI protection	disable(default) GFCI d15 081	Disable GFCI protection function.
		enable GFCI ENR 081	Enable GFCI protection function.
85	Ground detection function	disable GFD d15 085	Disable Ground detection function.
		enable(default) GFD ENR 085	Enable Ground detection function.

2) After pressing and holding UP and DOWN buttons at the same time for 3 seconds, the unit will enter PASS mode. Change the middle three numbers 000 to 305.

Program	Description	Setting Option	
35	Reset to factory settings	Reset: EE rst 035	Press the "ENTER" button twice to confirm the selection, then press "ESC" to return and complete the settings.

5. Parallel Installation Guide

Introduction

This inverter can be used in parallel with two different operation modes.

1. Parallel operation in Parallel expansion system with up to 9 units.
2. Maximum 9 units work together to support 3-phase equipment. 8 units support two phase maximum.

5.1 Parallel accessories

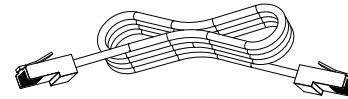

1. Parallel communication cable

5.2 Points of Attention for Parallel

- Ensure that all breakers in the line on the load side are disconnected.
- Be sure the length of all battery cables is the same. Otherwise, there will be voltage difference between inverter and battery to cause parallel inverters not working.
- Be sure that all inverters will share the same battery bank. Otherwise, the inverters will transfer to fault mode.
- Each inverter in the parallel system can only be connected to a separate PV string, and it is prohibited for multiple PV ports to share the same string, and there is a risk of blowing up the inverter.
- Recommended battery capacity

Inverter parallel numbers	2	3	4	5	6	7	8	9
SPE 12000 US-Battery Capacity	800AH	1200AH	1600AH	2000AH	2400AH	2800AH	3200AH	3600AH
SPE 10000 US-Battery Capacity	600AH	900AH	1200AH	1500AH	1800AH	2100AH	2400AH	2700AH
SPE 8000 US-Battery Capacity	600AH	900AH	1200AH	1500AH	1800AH	2100AH	2400AH	2700AH
SPE 6000 US-Battery Capacity	400AH	600AH	800AH	1000AH	1200AH	1400AH	1600AH	1800AH

5.3 Wire Connections

5.3.1 Parallel expansion system wire connection

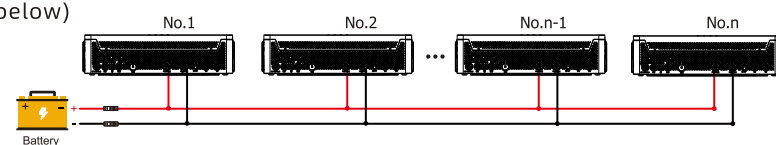
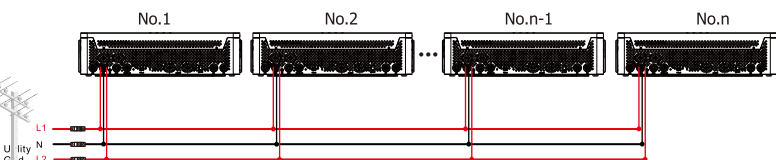
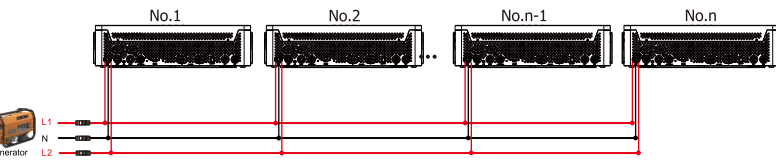
Parallel mode Port	Charts and descriptions
DC Input left-positive, right-negative	<p>When the inverters are connected in parallel, the + wires are connected together and the - wires are connected together at the DC input. (chart below)</p>  <p>In the inverter parallel system, each inverter battery needs to be connected to a DC circuit breaker, single access circuit breaker specifications recommended 400 A. If you choose to access the total circuit breaker at the system end, the recommended access circuit breaker specifications 400 A * the number of parallel (eg: four inverter system access to the total circuit breaker, the recommended access circuit breaker specifications 1600A).</p>
Grid	<p>When the inverters are connected in parallel, the N wires are connected together, the L1 wires are connected together and the L2 wires are connected together of each phase (chart below).</p>  <p>In an inverter-parallel system, an AC circuit breaker is required to be connected to the utility for each inverter, and a single access circuit breaker size of 70A is recommended.</p>
Generator	<p>When the inverters are connected in parallel, the N wires are connected together, the L1 wires are connected together and the L2 wires are connected together of each phase (chart below).</p> 

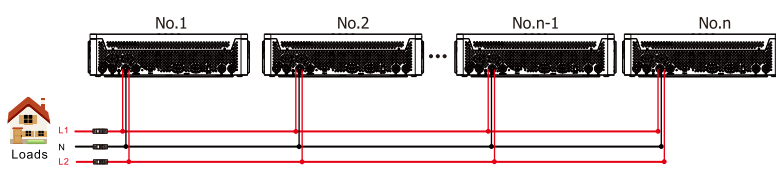
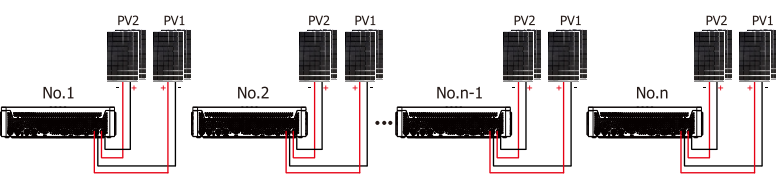
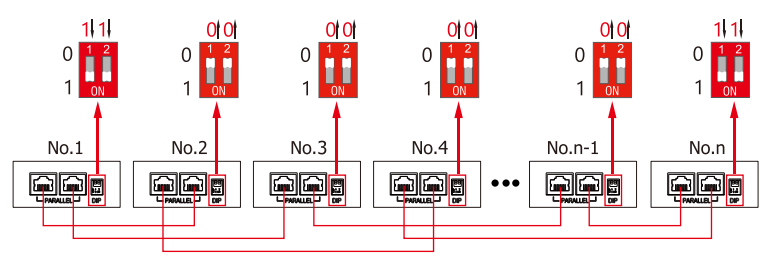
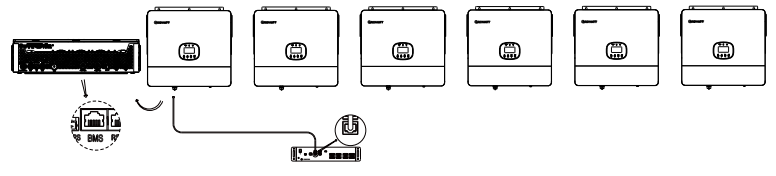
AC Output	<p>When the inverters are connected in parallel, the N wires are connected together, the L1 wires are connected together and the L2 wires are connected together of each phase (chart below).</p>  <p>In an inverter-parallel system, an AC circuit breaker is required to be connected to the load for each inverter, and a circuit breaker size of 70A is recommended.</p>
PV Input	<p>Each inverter in the system is individually connected to the PV string. (chart below)</p> 
Parallel communication port	<p>Please put the CAN communication DIP to on status for the first and the end inverter.</p> 
Lithium BMS Communication port	<p>Make sure to connect the BMS communication cable between the battery and one inverter of the parallel system. It's recommended to connect to the master inverter of the parallel system.</p> 

5.3.2 Three-phase parallel wire connection

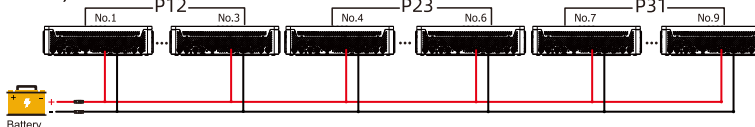
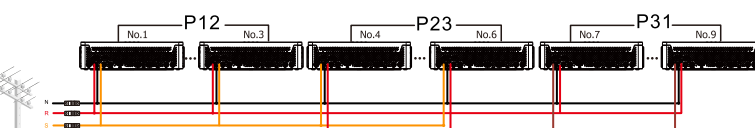
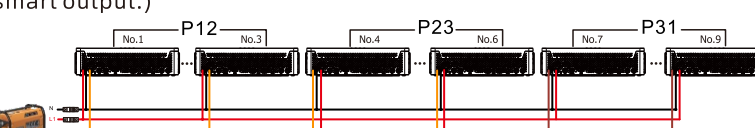
Parallel mode Port	Charts and descriptions
DC Input left-positive, right-negative	<p>When the inverters are connected in parallel, the + wires are connected together and the - wires are connected together of the DC input. (chart below)</p> 
	<p>In the inverter parallel system, each inverter battery needs to be connected to a DC circuit breaker, single access circuit breaker specifications recommended 400 A. If you choose to access the total circuit breaker at the system end, the recommended access circuit breaker specifications 400 A * the number of parallel (eg: four inverter system access to the total circuit breaker, the recommended access circuit breaker specifications 1600A)</p>
Grid	<p>After the inverter is connected in parallel, at the Grid, the N wires are connected together, the L1 wires are connected together and the L2 wires are connected together of each phase (chart below).</p> 
	<p>In an inverter-parallel system, an AC circuit breaker is required to be connected to the utility for each inverter, and a circuit breaker size of 70A is recommended.</p>
Generator	<p>After the inverter is connected in parallel, at the generator input or smart output, the N wires are connected together, the L1 wires are connected together and the L2 wires are connected together of each phase (chart below). (Refer to Program 90 for how to use them as generator input or smart output.)</p> 

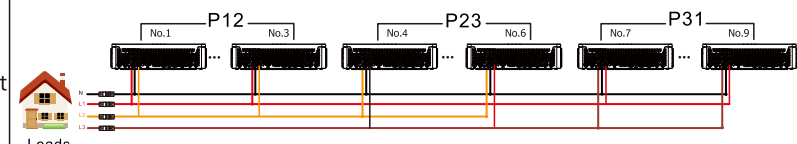
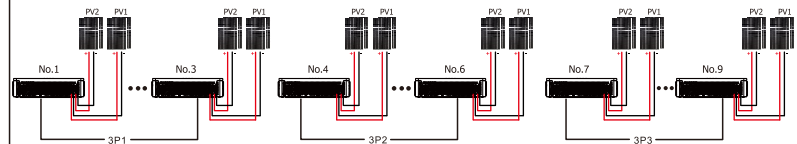
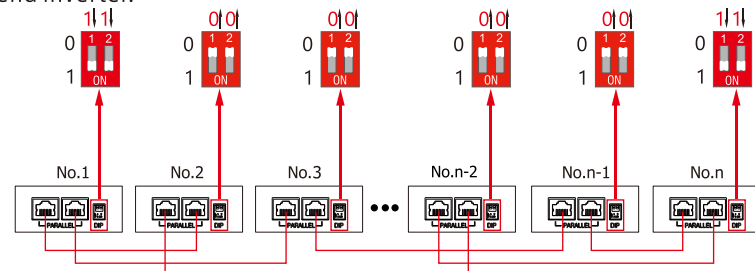
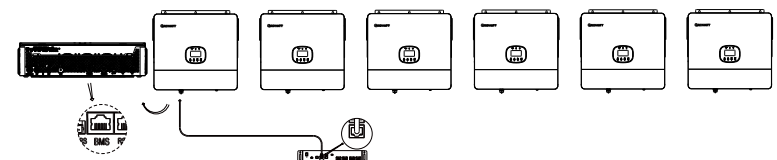
AC Output	<p>After the inverter is connected in parallel, at the AC output, the N wires are connected together, the L1 wires are connected together and the L2 wires are connected together of each phase (chart below).</p> 
	<p>In an inverter-parallel system, an AC circuit breaker is required to be connected to the utility for each load, and circuit breaker size of 70A is recommended.</p>
PV Input	<p>Each inverter in the system is individually connected to the PV string (chart below)</p> 
Parallel communication port	<p>Please put the CAN communication DIP to on status for the first and the end inverter.</p> 
Lithium BMS Communi	<p>Make sure to connect the BMS communication cable between the battery and one inverter of the parallel system. It's recommended to connect to the master inverter of the parallel system.</p> 

5.4 Parallel Example

Parallel Operation in Parallel expansion system

Parallel expansion system master and slave do not need to be set, the system automatically assigns the master and slave according to the order of start-up, the first one to start is the master, and the rest are the slaves. Be sure to confirm that the wiring is correct, the wiring is shown in the following figure. Nine inverters in parallel:

Power Connection

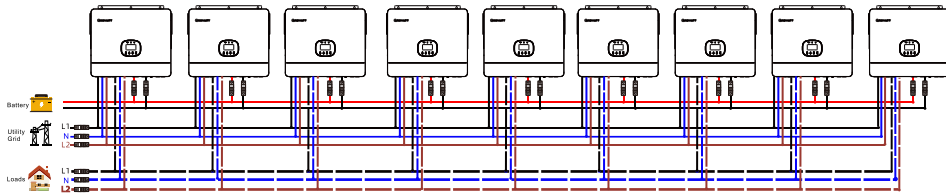

Parallel Operation in Three Phase

Try to connect to the utility at the same time after three-phase parallel connection.

When setting up three-phase parallel, you need to define the master and the slave, see the 5.5 for the specific setting method. Be sure to confirm that the wiring is correct, the wiring method is shown in the table below. The following chart is an example of (3+3+3) (1+1)

(3+3+3)Nine inverters for the three-phase (The number of inverters can be reduced, but there must be a P12 and a P23 or P31 to form a three-phase):
Power Connection

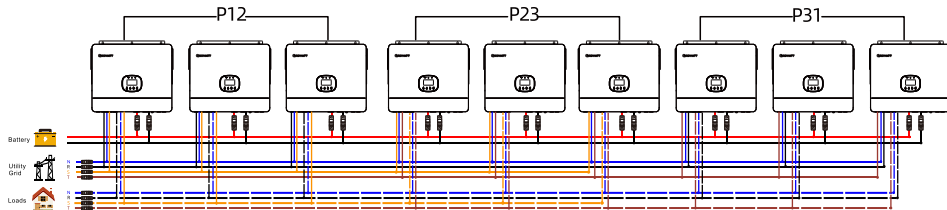

(1+1) Two inverters for the third phase:

Example: Two inverters form a three-phase connection:

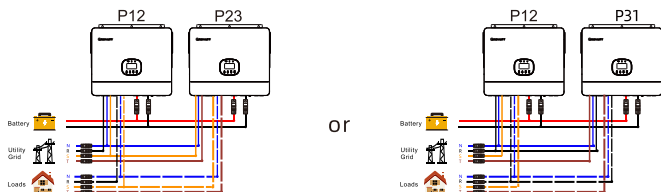

5.5 Parallel setup and display

Refer to Program 23 on Page 28

Parallel expansion system

Step 1: Check the following requirements before commissioning:

- Correct wire connection
- Ensure all breakers in Line wires of load side are open and each Neutral wires of each unit are connected together.

Step 2: Turn on each unit and set "PLV" in LCD setting program 23 of each unit. And then shut down all units.

Note: It's necessary to turn off switch when setting LCD program. Otherwise, the setting cannot be programmed.

Step 3: Turn on each unit.

LCD display in Master unit	LCD display in Slave unit

Note: Master and slave units are randomly defined.

Step 4: Switch on all AC breakers of Line wires in AC input. It's better to have all inverters connect to utility at the same time. If not, it will display warning 15.

LCD display in Master unit	LCD display in Slave unit

Step 5: If there is no more fault alarm, the parallel system is completely installed.

Step 6: Please switch on all breakers of Line wires in load side. This system will start to provide power to the load.

Three-phase parallel system

Step 1: Check the following requirements before commissioning:

- Correct wire connection
- Ensure all breakers in Line wires of load side are open and each Neutral wires of each unit are connected together. And the L lines of the same phase are connected together

Step 2: Turn on all units and configure LCD program 23 as P12, P23 and P31 sequentially. Then shut down all units.

Note: It's necessary to turn off switch when setting LCD program. Otherwise, the setting cannot be programmed.

Step 3: Turn on all units sequentially. Please turn on HOST inverter first, then turn on the rest one by one.

LCD display in R-S-phase	LCD display in S-T-phase	LCD display in T-R-phase

Step 4: Switch on all AC breakers of Line wires in AC input. If AC connection is detected and three phases are matched with unit setting, they will work normally. Otherwise, they will display warning 15/16 and will not work in the line mode.

LCD display in R-S-phase	LCD display in S-T-phase	LCD display in T-R-phase

Step 5: If there is no more fault alarm, the system to support 3-phase equipment is completely installed.

Step 6: Please switch on all breakers of Line wires in load side. This system will start to provide power to the load.

Note 1: If there's only one inverter in R-S-phase, the LCD will show as "HST". If there is more than one inverter in L1-phase, the LCD of the HOST inverter will show as "HST", the rest of R-S-phase inverters will show as "P12".

Note 2: To avoid overload occurring, before turning on breakers in load side, it's better to have whole system in operation first.

Note 3: Transfer time for this operation exists. Power interruption may happen to critical devices, which cannot bear transfer time.

Note 4: In the parallel expansion system with multiple inverters, when some inverters are connected to solar energy, energy can be obtained from the AC output end due to the parallel connection of the AC output end, resulting in energy transmission between inverters. Therefore, the AC input and AC output power displayed on the LCD display screen of a single inverter cannot accurately represent the energy flow of the inverter. It needs to be judged based on the total AC input and AC output power of the entire parallel system. (This phenomenon also exists between inverters in the same phase in a three-phase parallel system.)

6. Fault Reference Code

6.1 Fault Reference Code

Fault Code	Fault Event	Icon on
02	Over temperature	02
03	Battery voltage is too high	03
05	Output short circuited	05
06	Output voltage is too high.	06
07	Overload time out	07
08	Bus voltage is too high	08
09	Bus soft start failed	09
11	The main relay failed	11
12	The INV relay failed	12
51	Over current or surge	51
52	Bus voltage is too low	52
53	Inverter soft start failed	53
58	Output voltage is too low	58
60	Negative power fault	60
61	PV voltage is too high	61
62	Internal communication error	62
65	BUS voltage imbalance	65
66	GFCI is too high	66
67	DCI failed	67
70	Battery input overcurrent	70
80	CAN fault	80

6.2 Warning Indicator

Warning Code	Warning Event	Audible Alarm	Icon flashing
01	Fan is locked when inverter is on	Beep 3 times every second	01 [△]
02	Over temperature	Beep once every second	02 [△]
03	Battery is over-charged	Beep once every second	03 [△]
04	Low battery	Beep once every second	04 [△]
07	Overload	Beep once every 0.5 second	07 [△]
10	Output power derating	Beep twice every 3 seconds	10 [△]
13	Solar charger stops due to high PV voltage	Beep once every second	13 [△]
14	Solar charger stops due to overload	Beep once every second	14 [△]
15	Parallel input utility grid different	Beep once every second	15 [△]
16	AC input phase error	Beep once every second	16 [△]
17	Parallel output phase loss	Beep once every second	17 [△]
18	BUS over current	Beep once every second	18 [△]
19	Battery disconnect	No beep	19 [△]
20	BMS communication error	Beep once every second	20 [△]
21	PV power insufficient	Beep once every second	21 [△]
22	Parallel forbidden without battery	Beep once every second	22 [△]

23	The parallel version is different	Beep once every second	23 [△]
25	Parallel inverters' capacity different	Beep once every second	25 [△]
26	ISO detection failed	Beep once every second	26 [△]
27	Abnormal grounding warning	Beep once every second	27 [△]
28	GFCI error	Beep once every second	28 [△]
29	LLC overcurrent	Beep once every second	29 [△]
30	BUS low voltage	Beep once every second	30 [△]
31	Inconsistent switches	Beep once every second	31 [△]
36	Total over voltage	Beep once every second	36 [△]
37	Total under voltage	Beep once every second	37 [△]
38	Discharge over voltage	Beep once every second	38 [△]
39	Charge over voltage	Beep once every second	39 [△]
40	Discharge over temperature	Beep once every second	40 [△]
41	Charge over temperature	Beep once every second	41 [△]
81	Host loss	Beep once every second	81 [△]

7. Specifications

7.1 PV Specification

Model	SPE 12000 US	SPE 10000 US	SPE 8000 US	SPE 6000 US
Max. power	18000W	15000W	12000W	9000W
Max. PV Array Open Circuit Voltage	550Vdc			
Nominal PV Voltage	380Vdc			
PV Start-up Voltage	120Vdc±10V			
PV Array Voltage High Loss	550Vdc			
PV Array Voltage High Comeback	520Vdc			
PV Array Voltage Low Loss	60Vdc			
PV Array Voltage Low Back	120Vdc			
PV MPPT Voltage Range	60Vdc ~ 480Vdc			
PV MPPT Voltage Low Loss	60Vdc			
PV MPPT Voltage Low Back	75Vdc			
Number of MPP Trackers	2			
Max. input current per MPP tracker	27Amp	27Amp	27Amp	22Amp
Max. short-circuit current per MPP tracker	34Amp	34Amp	34Amp	28A
PV Voltage Accuracy	+/-5V			

7.2 AC Input Specification

Model	SPE 12000 US	SPE 10000 US	SPU 8000 US	SPU 6000 US
Nominal Input Voltage	120Vac(L-N)/240Vac(L1-L2)			
Low Loss Voltage	95Vac±7V(UPS); 65Vac±7V(Appliances); (L-N) 190Vac±7V(UPS); 130Vac±7V(Appliances); (L1-L2)			
Low Loss Return Voltage	100Vac±7V(UPS); 70Vac±7V (Appliances) ;(L-N) 200Vac±7V(UPS); 140Vac±7V (Appliances) ; (L1-L2)			
High Loss Voltage	140Vac±7V (L-N)/280Vac±7V(L1-L2)			
High Loss Return Voltage	135Vac±7V(L-N)/270Vac±7V(L1-L2)			
Max AC Input Voltage	150Vac(L-N)/300Vac(L1-L2)			
Nominal Input Frequency	50Hz / 60Hz (Auto detection)			
AC input frequency range	40±1Hz			
Low Loss Return Frequency	42±1Hz			
AC input frequency comeback value	65±1Hz			
High Loss Return Frequency	63±1Hz			
Max. AC Input current	70Amp (Include Loads and Charging)			
Rating of Transfer Relay	70Amp (Include Loads and Charging)			

7.3 Battery Mode Specification

Model	SPE 12000 US	SPE 10000 US	SPE 8000 US	SPE 6000 US
Nominal Output Power	12000W	10000W	8000W	6000W
Max Discharge Current	280A	240A	200A	140A
Waveform	Pure Sine Wave			
Nominal Output Voltage	120Vac(L-N)/240Vac(L1-L2)			
Nominal Output Frequency	50/60Hz auto sensing			
Output Voltage Distortion	<3% for linear load, <5% for non-linear load @ V nominal			
Output DC offset	<150mV			
Peak Efficiency	95%			
No Load Power Consumption	<75W@Rate Voltage			
Transfer Time	<20ms@Single <30ms @ Parallel			
Output Parallel-able	Yes			

7.4 Smart Load Output Power Specification

Model	SPE 12000 US	SPE 10000 US	SPE 8000 US	SPE 6000 US
Full Load Output Power	12000W	10000W	8000W	6000W
Maximum Main Load	12000W	10000W	8000W	6000W
Maximum smart load	12000W	10000W	8000W	6000W

7.5 Overload Capability Specification

Model	SPE 12000 US	SPE 10000 US	SPE 8000 US	SPE 6000 US
Line Mode	@>70A AC input current, 1 min			
Battery Mode	5sec, @>120% Load			
	10sec, @103%~120%			
	4-cycle, short-circuits			

7.6 Battery & Charger Specification

Model	SPE 12000 US	SPE 10000 US	SPE 8000 US	SPE 6000 US
Nominal DC Voltage	48Vdc			
Cold Start Voltage (Lead-Acid Mode)	46.0Vdc			
Cold Start SOC(Li Mode)	Default 30%, Low DC Cut-off SOC +10%			
Low DC Warning Voltage (Lead-Acid Mode)	44.0Vdc @ load < 20% 40.4Vdc @ load ≥ 50%			
Low DC Warning Recovery Voltage (Lead-Acid Mode)	46.0Vdc @ load < 20% 44.8Vdc @ 20% ≤ load < 50% 42.4Vdc @ load ≥ 50%			
Low DC Cut-off Voltage (Lead-Acid Mode)	42.0Vdc @ load < 20% 40.8Vdc @ 20% ≤ load < 50% 38.4Vdc @ load ≥ 50%			
Low DC Warning SOC (Li Mode)	Low DC Cut-off SOC +5%			
Low DC Warning Return SOC (Li Mode)	Low DC Cut-off SOC +10%			
Low DC Cut-off SOC(Li Mode)	Default 20%, 5%~50% settable			
High DC Recovery Voltage	56.4Vdc(C.V. charging voltage)			
High DC Cut-off Voltage	60Vdc			
Max. AC Charging Current	250Amp	220Amp	190Amp	140Amp
Max. Solar Charging Current	250Amp	220Amp	190Amp	140Amp
Max. Charging Current	250Amp	220Amp	190Amp	140Amp
Absorption Charging Voltage	56.4Vdc			
Floating Charging Voltage	54.0Vdc			
Overcharge Protection	60Vdc			
Charging Algorithm	3-step			
Charging process based on default setting. 3 stages: First - max. charging voltage increases to 56V; Second- charging voltage will maintain at 56V until charging current is down to 5 Amp, or after 12 hours of continuous charging; Third- go to floating charging at 54V.				

7.7 General Specification

Model	SPE 12000 US	SPE 10000 US	SPE 8000 US	SPE 6000 US
Operation Temperature Range	-10°C ~ 50°C			
Storage Temperature Range	-15°C ~ 60°C			
Altitude	< 2000m			
Relative humidity	5% ~ 95% non-condensing			
Audible Noise	<75dB			
Cooling	DC FAN			
Housing Dimension (L*W*H), mm	550*500*150 mm			
Packing Dimension (L*W*H), mm	705*625*260 mm			
Housing Color	White			
Net Weight, kg	21.7			
Gross Weight, kg	25.7			

8. Appendix

Appendix I. Fault information and processing

The energy storage inverter is designed according to the off-grid connected operation standard and meets the safety requirements and electromagnetic compatibility requirements. Before leaving the factory, the inverter undergoes several rigorous tests to ensure that the inverter can operate reliably.



If any of the fault messages listed in Table 6-1 appear on your inverter and the fault has not been removed after restarting, please contact your local dealer or service center. You need to have the following information ready.

1. Inverter serial number;
2. The problem description (including the fault code and indicator status displayed on the LCD, or specific fault video and picture) is as detailed as possible.
3. Basic system component information (such as batteries, photovoltaic panels, load usage and specifications)
4. Your contact information.

In order to give you a clearer understanding of the inverter's fault information, we will list all possible fault codes and their descriptions when the inverter is not working properly

error code	Description	Solutions
F01	Fan is locked	1. Check whether all fans are working properly. 2. Replace the fan.
F02	Internal temperature of component is over 100°C.	Check whether the air flow of the unit is blocked or whether the ambient temperature is too high.
F03	Battery is over-charged.	Restart the unit
	The battery voltage is too high	1.Measure battery voltage in DC input. (Check battery SOC in LCD when use Li battery) 2.Adjust the charging current to less than 0.2C 3.Check if spec and quantity of batteries are meet requirements.
W04	Battery voltage is too low	1.Measure battery voltage in DC input. (Check battery SOC in LCD when use Li battery) 2. Recharge the battery.
F05	Output short circuited	1.Disconnect load and restart the unit 2. Check if wiring is connected well and remove abnormal load.
F07	Overload time out	Reduce the connected load by switching off some equipment.
F08	Bus voltage is too high	1. If you connect to a lithium battery without communication, check whether the voltage points of the program 19 and 21 are too high for the lithium battery. 2. Restart the unit
F11/F12	Relay detection failed	Restart the unit
F09/F53 /F57	Bus soft start failed	Restart the unit
W15	The input status is different in parallel system	Check if AC input wires of all inverters are connected well.
W16	Input phase is not correct.	Change the input phase L1 and L2 wiring.
W17	The output phase not correct in parallel.	1.Make sure the parallel setting is the same System (Parallel expansion system or Three-phase parallel system; P12, P23, P31). 2.Make sure all phases inverters are power on.

W19	Lead acid battery disconnect	Check if spec and quantity of batteries are meet requirements.
	Lithium battery disconnect	1.Check BMS communication cable connection 2. Check setup parameters
W20	BMS communication error	1. Check whether communication line is correct connection between inverter and battery. 2. Check whether BMS protocol type is correct setting.
W27	Abnormal grounding warning	Check whether the ground connection is normal.
W31	Inconsistent switches	Check if all inverter switches are closed
F29/F51	Over current or surge	Restart the unit
F52	Bus voltage is too low	Restart the unit
F55	Output voltage is unbalanced	Restart the unit
F61	PV voltage is too high	1. Measure whether the PV voltage in the DC input is consistent with the value displayed on the LCD screen. 2. If consistent, standardize the parallel connection method of PV panels.
F62	Internal communication error	Restart the unit
F65	BUS voltage imbalance	Restart the unit
F66	GFCI is too high	1. Check if the load equipment has a leakage phenomenon 2. Restart the unit
F67	DCI failed	Restart the unit
F70	Battery input overcurrent	Reduce the connected load by switching off some equipment.
F80	CAN fault	1. Check whether the parallel communication cables are connected well.
F81	Host loss	2. Check whether Program 23 settings are right for the parallel system.

In order to give you a clearer understanding of the inverter's fault information, we will list all possible fault codes and their descriptions when the inverter is not working properly.

Other Problem	LCD/LED/Buzzer	Explanation	What to do
Unit shuts down Automatically during startup process.	LCD/LEDs and buzzer will be active for 3 seconds and then complete off.	The battery voltage is too low. (<1.91V/Cell)	1. Re-charge battery. 2. Replace battery.
No response after power on.	No indication.	1.The battery voltage is far too low. (<1.4V/Cell) 2.Battery polarity is connected reversed.	1. Check if batteries and the wiring are connected well. 2.Re-charge battery. 3.Replace battery.
Mains exist but the unit works in battery mode.	Input voltage is 0 on the LCD and green LED is flashing.	Input protector is tripped.	Check if AC breaker is tripped and AC wiring is connected well.
	Green LED is flashing.	Insufficient quality of AC power (Shore or Generator)	1. Check if AC wires are too thin and/or too long. 2.Check if generator (if applied) is working well or if input voltage range setting is correct. (UPS → Appliance)
	Green LED is flashing.	Set "Battery First" or "Solar First" as the priority of output source.	Change output source priority to Utility first.
When it's turned on, internal relay is switching on and off repeatedly.	LCD display and LEDS are flashing	Battery is disconnected.	Check if battery wires are connected well.

Note: To restart the inverter, all power sources need to be disconnected. After the LCD screen light is off, only use the battery to boot.

Appendix II Restore factory settings

After pressing and holding UP and DOWN buttons at the same time for 3 seconds, the unit will enter PASS mode. Change the middle three numbers 000 to 305. Press the "ENTER" button twice to confirm the selection, then press "ESC" to return and complete the settings.

Program	Setting Option
PASS	PASS 305 000

Appendix III Battery Equalization

43	Battery equalization	Battery equalization enable EQ ENA 043	Battery equalization disable(default) EQ DIS 043
		If "Flooded" or "User-Defined" is selected in program 05, this program can be set up.	
44	Battery equalization voltage	EQV 584 044 Default 58.4V, 48.0V~58.4V Settable	
45	Battery equalized time	EQE 60 045	Default 60min, 5min~900min Settable
46	Battery equalized timeout	EQE0 120 046	Default 120min, 5min~900min Settable
47	Equalization interval	EQI 30 047	Default 30days, 1 days~90 days Settable
48	Equalization activated immediately	Equalization activated immediately on EQ ON 048	Equalization activated immediately off(default) EQ OFF 048
		If equalization function is enabled in program 43, this program can be setup. If "On" is selected in this program, it's to activate battery equalization immediately and LCD main page will shows "	

Equalization function is added into charge controller. It reverses the buildup of negative chemical effects like stratification, a condition where acid concentration is greater at the bottom of the battery than at the top. Equalization also helps to remove sulfate crystals that might have built up on the plates. If left unchecked, this condition, called sulfation, will reduce the overall capacity of the battery. Therefore, it's recommended to equalize battery periodically.

- How to Apply Equalization Function?

You must enable battery equalization function in monitoring LCD setting program 43 first. Then, you may apply this function in device by either one of following methods:

1. Setting equalization interval in program 47.
2. Active equalization immediately in program 48.

- When to Equalize

In float stage, when the setting equalization interval (battery equalization cycle) is arrived, or equalization is active immediately, the controller will start to enter Equalize stage.

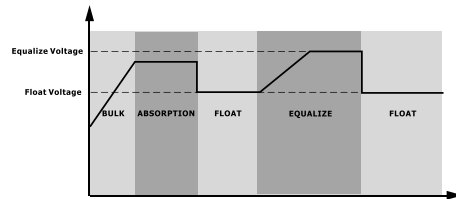

- Equalize charging time and timeout

In Equalize stage, the controller will supply power to charge battery as much as possible until battery voltage raises to battery equalization voltage. Then, constant-voltage regulation is applied to maintain battery voltage at the battery equalization voltage. The battery will remain in the Equalize stage until setting battery equalized time is arrived.

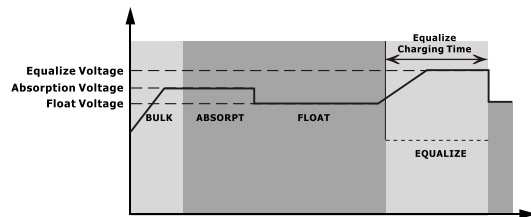

However, in Equalize stage, when battery equalized time is expired and battery voltage doesn't rise to battery equalization voltage point, the charge controller will extend the battery equalized time until battery voltage achieves battery equalization voltage. If battery voltage is still lower than battery equalization voltage when battery equalized timeout setting is over, the charge controller will stop equalization and return to float stage.

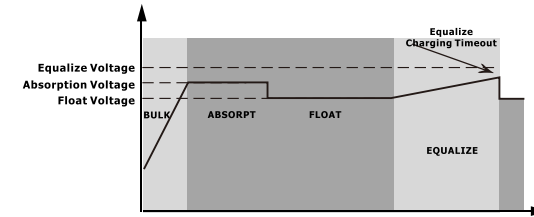

Appendix IV Routine maintenance

To ensure the long-term and good operation of the energy storage system, it is recommended to perform the routine maintenance as described in this section (Cleaning and maintenance of the inverter must be carried out with the power supply disconnected to ensure personal safety.)

Items	Methods	Maintenance interval
System cleanliness for inverter	<ul style="list-style-type: none"> • Regularly check the surface of the inverter for dust or other debris and clean it with a dust sponge. 	Once every six months to one year
	<ul style="list-style-type: none"> • Regularly check that radiators and vents are not covered with dust and clean them with a soft brush or compressed air. Remove the dustproof cotton at the air inlet and clean it. 	Once every 3 months.
Electrical connection	<ul style="list-style-type: none"> • Check if any cable connection is off or loose. • Check if any cable is damaged, and especially if there are cuts on the sheath where the cable contacts with the metal surface. 	Half a year after first debugging and testing, and once every six months to one year thereafter.
	Check the internal circuit boards and components of the inverter for abnormalities, such as damage, discoloration, etc., and repair and replace them in a timely manner.	
Grounding reliability	Check if the grounding cable is grounded reliably.	

Normal operation	Periodically check the input voltage, output voltage and current of the inverter to ensure that it is operating within its rated range.	
	Regularly check the operating status and performance parameters of the inverter via the inverter's monitoring system or display.	
Other Maintenance	Ensure that the inverter is installed in a dry, well-ventilated environment, protected from humidity, heat or excessive dust.	

Appendix V WIFI Monitoring

Plug cube WIFI into the WIFI/4G port. Scan the QR code below to download ShinePhone, also you can search ShinePhone in iOS or Google Play Store, download and install it.

Note: 1. Make sure you download the latest version.
2. For further information please visit server. growatt.com

