



NEO 1600M-X2  
NEO 1800M-X2  
NEO 2000M-X2  
NEO 2250M-X2  
NEO 2500M-X2

# Installation & Operation Manual

## **Important Notice**

Copyright © 2024 Shenzhen Growatt New Energy Co., Ltd. All rights reserved. No part of this document may be reproduced, stored in a retrieval system, or transmitted, in any form or by any means, electronic, mechanical, photographic, magnetic or otherwise, without the prior written permission of Shenzhen Growatt New Energy Co., Ltd.

Shenzhen Growatt New Energy Co., Ltd. (hereinafter referred to as Growatt) makes no representations, express or implied, with respect to this documentation or any of the equipment and/or software it may describe, including (with no limitation) any implied warranties of utility, merchantability, or fitness for any particular purpose. All such warranties are expressly disclaimed. Neither Growatt nor its distributors or dealers shall be liable for any indirect, incidental, or consequential damages under any circumstances.

(The exclusion of implied warranties may not apply in all cases under some statutes, and thus the above exclusion may not apply.)

The content of this manual is constantly reviewed and subject to change without notice. Every attempt has been made to make this document complete, accurate and up-to-date. Readers are cautioned, however, that Growatt reserves the right to make changes without notice and shall not be responsible for any damages, including indirect, incidental or consequential damages, caused by reliance on the material presented, including, but not limited to, omissions, typographical errors, arithmetical errors or listing errors in the content material.

This manual will be updated frequently. Please refer to Growatt website at [en.growatt.com](http://en.growatt.com) for the latest version.

All trademarks are recognized even if these are not marked separately. Missing designations do not mean that a product or brand is not a registered trademark.

# Contents

<b>1 Notes on this manual</b>	<b>1</b>
1.1 Introduction	1
1.2 Target Group	1
1.3 Additional information	1
1.4 Symbols in this document	1
1.4.1 Warning symbols in this document	1
1.4.2 Markings on this product	2
1.5 Radio Interference Statement	3
<b>2 Safety</b>	<b>4</b>
2.1 Intended Use	4
2.2 Installation personnel requirements and Grid connection approval	4
2.3 Safety instructions	4
2.4 Installation Warnings	5
2.5 Electrical Connection Warnings	5
2.6 Operation Warnings	6
<b>3 Product description</b>	<b>7</b>
3.1 Overview	7
3.2 Nameplate	7
3.3 Dimensions and weight	8
3.4 Highlights	8
<b>4 Microinverter Installation</b>	<b>9</b>
4.1 Safety instructions	9
4.2 Decisive Voltage Class (DVC) indicated for ports	10
4.3 Microinverter system	10
4.4 Selection of the Over Current Protection Device and the Cable	11
4.5 Accessories	12
4.6 Installation Steps	12
<b>5 Troubleshooting</b>	<b>23</b>
5.1 Error Messages	23
5.2 System faults	23
5.3 Inverter warnings	24
5.4 Inverter faults	25
5.5 LED Indicator Status	26

5.6 Microinverter Replacement.....	27
<b>6 Warranty.....</b>	<b>28</b>
<b>7 Decommissioning.....</b>	<b>29</b>
7.1 Removing the Microinverter .....	29
7.2 Packing theMicroinverter .....	29
7.3 Storage and Transportation.....	29
7.4 Disposal.....	29
<b>8 Technical Data .....</b>	<b>30</b>
8.1 Specifications .....	30
8.2 DC connector info.....	32
8.3 Torque .....	32
<b>9 Declaration of conformity .....</b>	<b>33</b>
<b>10 Contact .....</b>	<b>34</b>

# 1 Notes on this manual

## 1.1 Introduction

This manual describes the assembly, installation, troubleshooting and maintenance of the following Microinverters manufactured by Shenzhen Growatt New Energy Co.,Ltd. (hereinafter referred to as Growatt):

- NEO 1600M-X2
- NEO 1800M-X2
- NEO 2000M-X2
- NEO 2250M-X2
- NEO 2500M-X2

## 1.2 Target Group

This manual is intended for qualified personnel. Qualified personnel should have received training and have demonstrated skills and knowledge in the construction and operation of this device. Qualified personnel are trained to deal with the dangers and hazards involved in installing electrical devices.



## 1.3 Additional information



Find further information on special topics in the download area at [en.growatt.com](http://en.growatt.com). The manual and other documents must be stored in a convenient place and be available at all times. We assume no liability for any damage caused by failure to observe instructions specified in this document. For possible changes in this manual, Growatt accepts no responsibilities to inform the users.

## 1.4 Symbols in this document











### 1.4.1 Warning symbols in this document

The warning symbols warn against improper operations, which may cause personal injury or device damage. Prior to installing and operating the NEO Microinverter, please familiarize yourself with the symbols and their meanings.

Symbol	Meaning
 <b>DANGER</b>	DANGER indicates a hazardous situation which, if not avoided, will result in death or serious injury.
 <b>WARNING</b>	WARNING indicates a hazardous situation which, if not avoided, could result in death or serious injury.

Symbol	Meaning
 <b>CAUTION</b>	CAUTION indicates a hazardous situation which, if not avoided, could result in minor or moderate injury.
 <b>NOTICE</b>	NOTICE is used to address practices not related to personal injury.

#### 1.4.2 Markings on this product

Label	Description
	Risk of high voltages which might lead to electric shocks
	Risk of fire or explosion
	Risk of burns due to hot surface
	Residual voltage exists after the Microinverter is powered off. Wait for 5 minutes before performing any operation.
	Grounding: indicates the position for connecting the PE cable
	Direct Current (DC)
	Alternating Current (AC)
	Refer to the manual
	CE marking This product complies with the requirements of the applicable EU directives.
	Do not dispose of the product together with the household waste but in accordance with the disposal regulations for electronic waste applicable at the installation site

## 1.5 Radio Interference Statement

The equipment can comply with CE EMC, which are designed to protect against harmful interference in a residential installation. This equipment generates, uses and can radiate radio frequency energy and, if not installed and used in accordance with the instructions, may cause harmful interference to radio communications. However, there is no guarantee that interference will not occur in a particular installation. If this equipment does cause harmful interference to radio or television reception, which can be determined by turning the equipment off and on, you are encouraged to try to correct the interference by one or more of the following measures:

- Reorient or relocate the receiving antenna.
- Increase the separation between the equipment and the receiver.
- Connect the equipment into an outlet on a circuit different from that to which the receiver is connected.

Keep a safe distance of at least 20 cm from the microinverter at all times.

Growatt assumes no responsibility for compliance to EMC regulations for the entire system.

## 2.1 Intended Use

The NEO Microinverter converts the DC power generated by the photovoltaic (PV) modules to single-phase and grid-compliant AC power and feeds the energy to the grid.

Working principle of a PV plant with the NEO Single-phase Microinverter

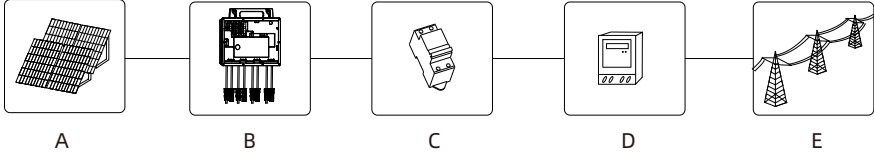

Position	Description
A	PV modules
B	Microinverter
C	AC load circuit breaker
D	Energy meter
E	Utility grid

The NEO Microinverter should be operated with a permanent connection to the public grid. It is not intended for mobile use. Any use of the product other than that described in the Intended Use section does not qualify as appropriate. Damages caused by improper use are beyond the scope of warranty and should be the responsibility of the user.



## 2.2 Installation personnel requirements and Grid connection approval

Only qualified and well-trained personnel are permitted to install the NEO Microinverter. Prior to installing the equipment, ensure that it is permitted by the local authority. The NEO Microinverter can only operate when it is properly connected to the grid. Before connecting it to the public grid, ensure that you have consulted the responsible grid operator and obtain any approval needed.



## 2.3 Safety instructions

The NEO Microinverter is designed and tested according to international safety requirements. As with all electrical devices, there are residual risks despite careful construction. Improper use may cause fatal hazards to the operator, device damages and property loss. Therefore, it is essential to read through the instruction manual carefully while also ensuring compliance with the safety instructions during use. Should you encounter any problems, please contact Growatt support at +86 755 2747 1942.



## 2.4 Installation Warnings

 <p><b>WARNING</b></p>	<ul style="list-style-type: none"> <li>➤ Prior to installation, check if there is any damage caused during transportation or handling, which might affect the insulation integrity and the safety performance. Failure to do so may lead to personal injury and device damage.</li> <li>➤ Unauthorized removal of necessary protection devices, improper use, incorrect installation and operation may lead to serious safety hazards and/or equipment damage.</li> <li>➤ In order to minimize the potential of a shock hazard due to high voltages, cover the entire solar module with dark material prior to connecting it to any equipment.</li> </ul>
 <p><b>CAUTION</b></p>	<ul style="list-style-type: none"> <li>➤ Ground the Microinverter and the PV module rack in compliance with local requirements to avoid personal injury and device damage.</li> </ul>

## 2.5 Electrical Connection Warnings

 <p><b>DANGER</b></p>	<ul style="list-style-type: none"> <li>➤ High voltages are present in the conductive components of the product. Touching live parts could result in death or lethal injuries due to electric shock.             <ul style="list-style-type: none"> <li>• Do not remove the cover of the Microinverter.</li> <li>• Only professional electricians are permitted to install, repair and replace the equipment.</li> <li>• Do not touch damaged Microinverters.</li> </ul> </li> <li>➤ Danger to life due to high voltages in the Microinverter             <ul style="list-style-type: none"> <li>• Residual voltage exists after the Microinverter is powered off. Wait for 5 minutes before performing any operation.</li> </ul> </li> <li>➤ Persons with limited physical or mental abilities may only work with the Growatt Microinverter following proper instructions and under constant supervision.</li> <li>➤ Ensure that the Microinverter is inaccessible to children.</li> </ul>
 <p><b>WARNING</b></p>	<ul style="list-style-type: none"> <li>➤ Perform all electrical connections (e.g. conductor termination, PE connection, etc.) in accordance with locally applicable regulations. When working with the inverter powered on, adhere to all prevailing safety regulations to minimize the risk of accidents.</li> <li>➤ Solar systems with inverters typically require additional control devices (e.g. switches, disconnects) or protective devices (e.g. fuse, circuit breakers). Choose specific types of control and protective devices depending on the prevailing safety rules.</li> </ul>

## 2.6 Operation Warnings

 <p><b>WARNING</b></p>	<ul style="list-style-type: none"><li>➤ Ensure all connectors are sealed and secured during operation.</li><li>➤ Some surfaces of the Microinverter may become hot during operation. To reduce the risk of injury, do not touch the product while it is in operation.</li><li>➤ If an incorrect number of PV modules are connected in parallel, it might cause high PV voltage, damaging the device.</li><li>➤ Disconnect the device from the AC power source before disconnecting the PV module.</li></ul>
 <p><b>CAUTION</b></p>	<ul style="list-style-type: none"><li>➤ All operations regarding transportation, installation, commissioning and maintenance must be operated by qualified and well-trained personnel and in compliance with all prevailing codes and regulations.</li><li>➤ Once the Microinverter is disconnected from the grid, operate with extreme caution as some components may retain charge which might cause an electric shock.</li><li>➤ In special cases, interference may occur in a particular installation despite adhering to standardized emission limits. For example, when the sensitive equipment is located at the setup location or when the setup location is near radio or television receivers. In this case, the operator is obliged to take proper action to clear the interference.</li><li>➤ Keep a safe distance of at least 20 cm from the inverter at all times.</li></ul>

# 3 Product description

## 3.1 Overview

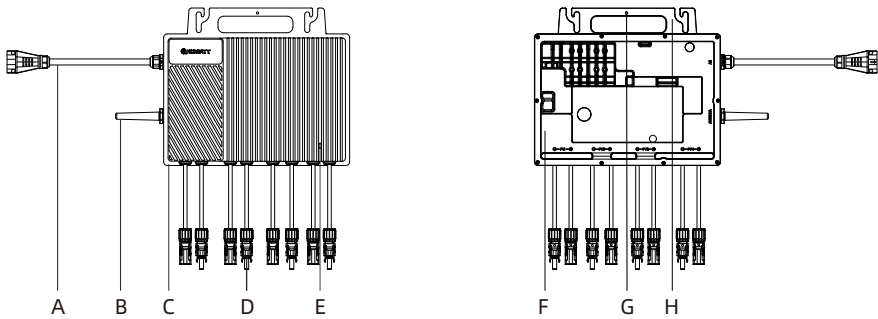

Position	Description
A	AC cable
B	Antenna
C	Heat sink
D	PV terminal
E	LED
F	Back plate
G	Grounding hole
H	Handle

## 3.2 Nameplate

The nameplate provides a unique identification of the Microinverter, including the model of the product and the device-specific characteristics.

**GROWATT**  
PV Micro Inverter  
Inversor FV Grid-tie  
NEO 2500M-X2

Max PV voltage Tensão c.c. Máxima	<b>60 d.c.V</b>	Max. output current Corrente c.a. Máxima	<b>11.36 a.c.A</b>
PV voltage range Faixa de tensão PV	<b>16 - 60 d.c.V</b>	Nominal output frequency Frequência de saída nominal	<b>50/60 Hz</b>
PV Isc Corrente de curto circuito PV (Isc)	<b>20 d.c.A*4</b>	Power factor range Fator de Potência	<b>0.8 Capacitivo~0.8 Indutivo</b>
Max. input current Corrente c.c. Máxima	<b>18 d.c.A*4</b>	Safety level Nível de segurança	<b>Class I</b>
Max. output power Potência c.a. Máxima	<b>2500 W</b>	Ingress protection Grau de Proteção IP	<b>IP67</b>
Max. apparent power Potência v.a. Máxima	<b>2500 VA</b>	Operation ambient temperature Faixa de temperatura de Operação	<b>-40°C ~ +65°C</b>
Nominal output voltage Tensão c.a. Nominal	<b>220 a.c.V</b>		

Shenzhen Growatt New Energy Co., Ltd.  
4-13/F, Building A, Sino-German (Europe) Industrial Park,  
Kuangsheng Ave, Bao'an District, Shenzhen, China

**Made in China**  
Feito na China

X

### 3.3 Dimensions and weight

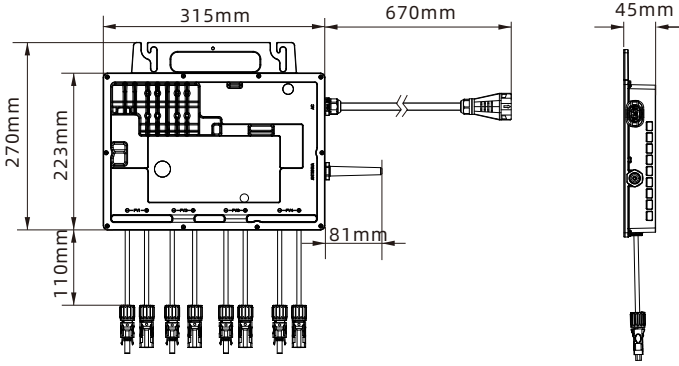

Dimensions and weight





Model	Width (W)	Height (H)	Depth (D)	Weight
NEO 1600-2500M-X2	396 mm	270 mm	45mm	5.1 kg

### 3.4 Highlights

- Wide input voltage range: Wide MPP voltage range 16-55VDC
- 4 independent MPP trackers
- High-performance LoRa communication with ShineWeLink
- IP67-rated (NEMA 6) enclosure

# 4 Microinverter Installation

## 4.1 Safety instructions

	<p>Danger to life due to high voltages! High voltages which may cause electric shocks are present in the conductive parts of the Microinverter. Prior to performing any operations on the Microinverter, disconnect the device from all power sources.</p>
	<p>Danger to life due to fire or explosion</p> <ul style="list-style-type: none"><li>➤ Do not install or use in potentially flammable and explosive atmospheres.</li><li>➤ Do not allow terminator to come in contact with open flame.</li></ul>
	<p>Risk of burns due to hot enclosure parts The Microinverter should be protected against accidental contact The microinverter generates heat when it is in operation. Do not touch the enclosure of the device; otherwise, it might result in burns.</p>
	<p>Electromagnetic Radiation The equipment can comply with CE EMC, which are designed to protect against harmful interference in a residential installation. This equipment generates, uses and can radiate radio frequency energy and, if not installed and used in accordance with the instructions, may cause harmful interference to radio communications. However, there is no guarantee that interference will not occur in a particular installation. If this equipment does cause harmful interference to radio or television reception, which can be determined by turning the equipment off and on, you are encouraged to try to correct the interference by one or more of the following measures:</p> <ul style="list-style-type: none"><li>➤ Reorient or relocate the receiving antenna.</li><li>➤ Increase the separation between the equipment and the receiver.</li><li>➤ Connect the equipment into an outlet on a circuit different from that to which the receiver is connected.</li></ul> <p>Keep a safe distance of at least 20 cm from the microinverter at all times. Growatt assumes no responsibility for compliance to EMC regulations for the entire system.</p>
 <b>WARNING</b>	<p>Do not disassemble the microinverter by yourself</p> <ul style="list-style-type: none"><li>➤ Do not disassemble the microinverter by yourself to avoid device damage.</li><li>➤ If you encounter any issue about the microinverter that cannot be solved, please contact Growatt supplier.</li></ul>

### 4.2 Decisive Voltage Class (DVC) indicated for ports

Port Name	Class
AC	C
DC	C

### 4.3 Microinverter system

The figure below shows the two Microinverter PV system configurations:

WiFi version: Growatt NEO Microinverter + WiFi Router

LoRa version: Growatt NEO Microinverter + Shine WeLink + WiFi Router

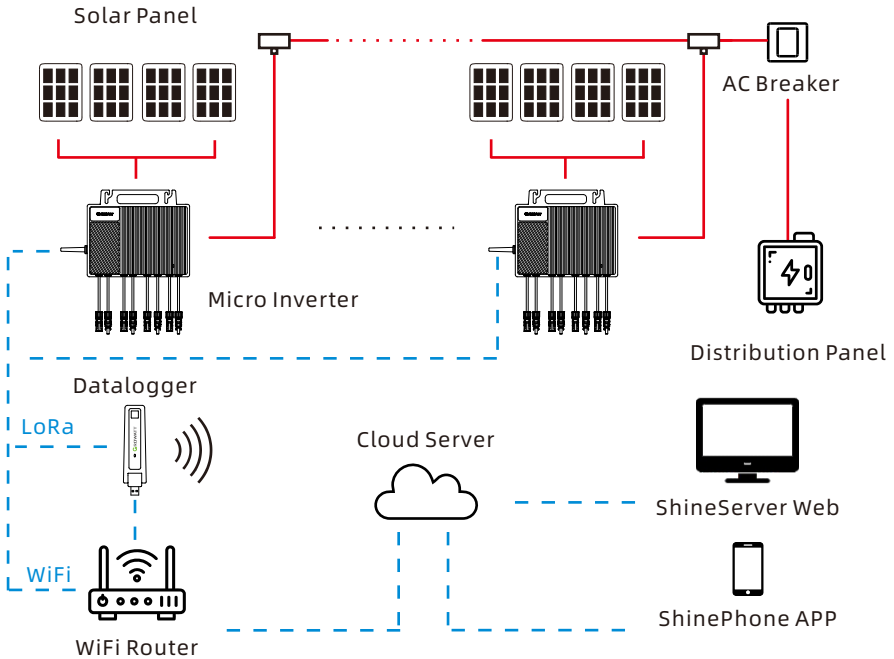

 <b>NOTICE</b>	<p>The NEO Microinverter supports both WiFi and LoRa communication. For remote monitoring, the Microinverter with integrated LoRa module should be connected to ShineWeLink.</p> <p>If the WiFi signal is weak, please install a WiFi booster at a suitable place between the microinverter and the router.</p> <p>Position the ShineWeLink next to the router, but maintain a minimum distance of 0.5m to avoid distortion resulting from the excessively strong signal.</p> <p>Do not place the inverter, the router and Welink on the same vertical line to avoid affecting the signal strength.</p>
----------------------------------------------------------------------------------------------------	---------------------------------------------------------------------------------------------------------------------------------------------------------------------------------------------------------------------------------------------------------------------------------------------------------------------------------------------------------------------------------------------------------------------------------------------------------------------------------------------------------------------------------------------------------------------------------------------------------

#### 4.4 Selection of the Over Current Protection Device and the Cable

1. Growatt NEO Microinverters can be connected using the 12 AWG or 10 AWG AC trunk cable and the AC trunk connector. The limits on the number of Microinverters on each AC branch shown below should be strictly adhere to.

	NEO 1600M -X2	NEO 1800M -X2	NEO 2000M -X2	NEO 2250M -X2	NEO 2500M -X2	Max. over current protection device
Maximum number per 12AWG AC trunk cable	3pcs	3pcs	2pcs	2pcs	2pcs	25A
Maximum number per 10AWG AC trunk cable	4pcs	3pcs	3pcs	2pcs	2pcs	32A

2. For connection to the Male AC Sub Connector, it is recommended to use the 14 AWG AC cable. The recommended cable length must be strictly adhered to.

Cable suggestion length:

Cable	Max.cable length				
	NEO 1600M-X2	NEO 1800M-X2	NEO 2000M-X2	NEO 2250M-X2	NEO 2500M-X2
14AWG	35m	30m	25m	20m	20m
16AWG	20m	15m	15m	10m	10m

## 4.5 Accessories

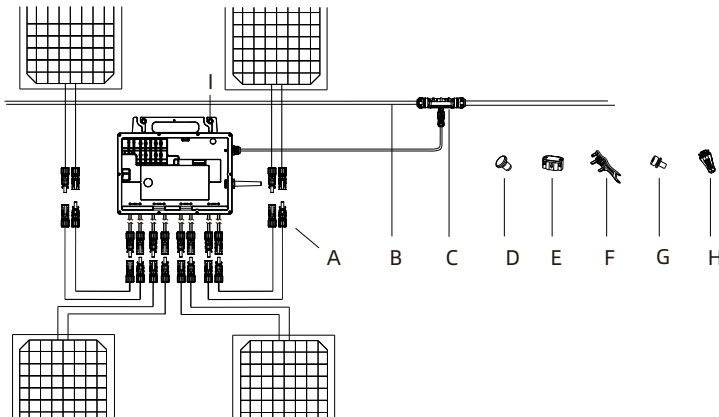





Position	Description
A	PV Extension Cable
B	AC Trunk Cable (AWG 12/10)
C	AC Trunk Connector
D	AC Trunk End Cap
E	AC Trunk Port Cap
F	AC Connector Unlock Tool
G	Grounding screw (M4*6)
H	Male AC Sub Connector
I	Mounting screw (M8*22)

**NOTE:** All accessories listed above are not included in the package and should be purchased separately.

## 4.6 Installation Steps

 <b>WARNING</b>	<ul style="list-style-type: none"> <li>➤ It is recommended to use AWG 12 or 10 cables when the AC Trunk Connector is used.</li> <li>➤ It is recommended to use AWG 14 cable when the Male AC Sub Connector is used.</li> <li>➤ Consider the maximum current of the AC trunk cable concerning the maximum number of Microinverters permitted for installation.</li> </ul>
-------------------------------------------------------------------------------------------------------	--------------------------------------------------------------------------------------------------------------------------------------------------------------------------------------------------------------------------------------------------------------------------------------------------------------------------------------------------------------------------

 <b>WARNING</b>	<p>The solar modules connected to the inverter must conform to the Class A requirements of the IEC 61730 standard.</p> <ul style="list-style-type: none"> <li>➤ Please use male and female PV connectors of the same brand.</li> </ul>
 <b>WARNING</b>	<p>Danger to life due to lethal voltages!</p> <ul style="list-style-type: none"> <li>➤ The PV module generates voltage when exposed to sunlight, which might cause personal injury. Therefore, cover the entire solar module with dark material prior to connecting it to the Microinverter and ensure that the AC breaker is disconnected.</li> <li>➤ NEVER connect or disconnect the DC connectors under load.</li> <li>➤ Make sure the maximum open circuit voltage (Voc) of each PV string is less than the maximum input voltage of the inverter.</li> <li>➤ Check the design of the PV plant. The Max. open-circuit voltage, which may occur when the temperature of the solar panel is -40°C, must not exceed the Max. input voltage of the inverter.</li> </ul>
 <b>WARNING</b>	<p>Improper operation during the wiring process can cause fatal injury to operators or unrecoverable damage to the inverter. Only qualified personnel can perform the wiring work.</p> <ul style="list-style-type: none"> <li>➤ Check the connection cables of the PV modules for correct polarity and make sure that the maximum input voltage of the inverter is not exceeded.</li> </ul>
 <b>NOTICE</b>	<p>We advise to install a RCD breaker only if it is required by the local electrical code. Growatt recommends the use of a type-A RCD breaker with a rated residual current over 100 mA.</p>
 <b>NOTICE</b>	<p>The sequence can be changed based on your installation plan. When crimping the AC trunk cable, a hexagonal wire crimper must be used.</p>

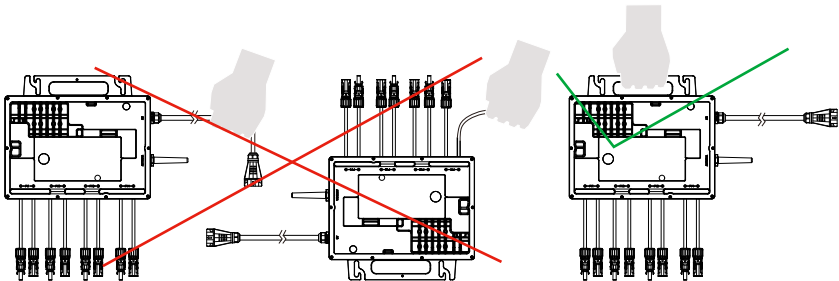

 <b>WARNING</b>	<p>Do not carry the Microinverter by pulling the AC cable or the PV cable. Hold the handle instead.</p>
-------------------------------------------------------------------------------------------------------	---------------------------------------------------------------------------------------------------------

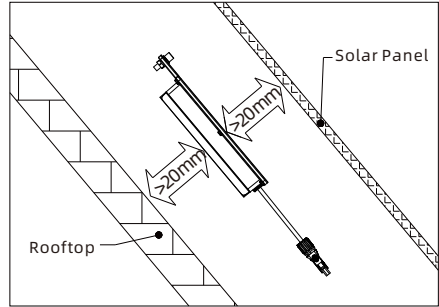
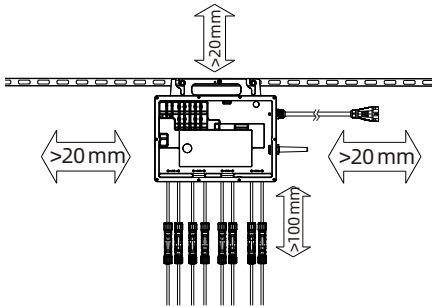

**NOTICE**

Reserve a clearance of at least 20 mm around the Microinverter to ensure sufficient space for ventilation and heat dissipation.

### Step 1 Install the Microinverter

- Mark the location of the Microinverter on the rack with respect to the arrangement of the PV modules.
- Mount the Microinverters at the marked positions using accessories recommended by your module racking vendor.

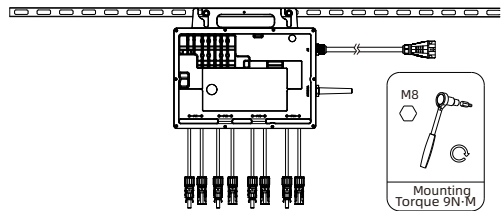
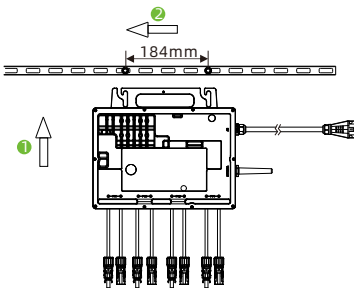

## Step 2 Ground the system

- a) The AC cable has an embedded earth wire, which might be sufficient to ensure proper grounding.
- b) In areas with special grounding requirements, external grounding can be done by grounding the screw hole on the handle.

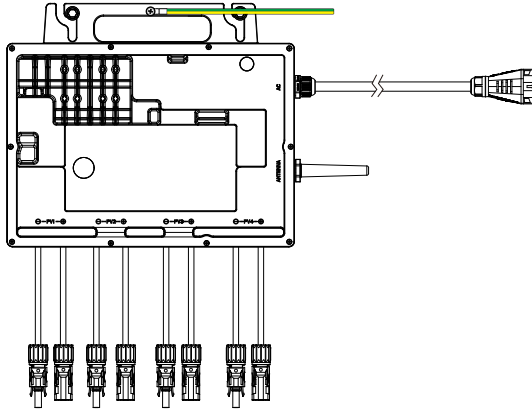

## Step 3 Connect the AC cable

- Use the AC Trunk Connector, which is applicable to the system with a single Microinverter or multiple Microinverters.
  - a) Connect the Microinverter to the distribution panel using an AC Trunk Cable.
    - 1. Check the spacing between the Microinverters.
    - 2. Determine the number of Microinverters that will be installed on each branch and prepare the AC Trunk Cable and the AC Trunk Cable accordingly.
    - 3. There are two ways to build an AC Trunk Cable:
      - a) if an AC Trunk Cable with multiple AC Trunk Connectors is available, you can take out the segments of the AC Trunk Cable to make AC branch ;
      - b) you can build an AC Trunk Cable with AC Trunk Connectors and cables.
  - b) Disassemble the AC Trunk Connector and remove the cable from one end.
    - 1. Unlock the connector's bottom cover using the AC Connector Unlock Tool.

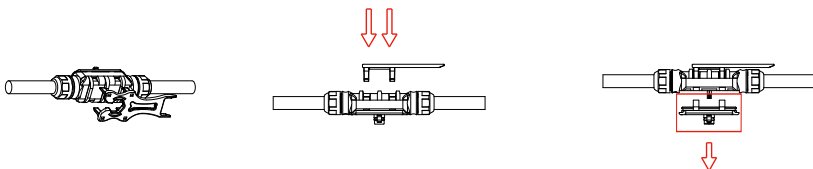

2. Loosen the three screws with the screwdriver, untighten the cap and remove the cable.

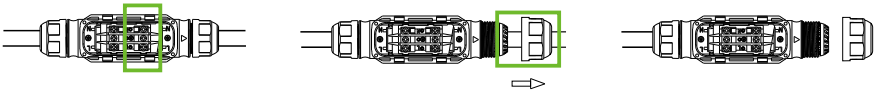

3. Install the AC Trunk End Cap at one side of AC Trunk Cable.



4. Install the cover back to the AC Trunk Connector.

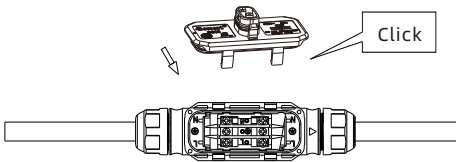

c) Build an AC Trunk Cable with AC Trunk Connectors and cables:

1. Insert the AC Trunk End cap and screw the cap back to port, then tighten the cap.

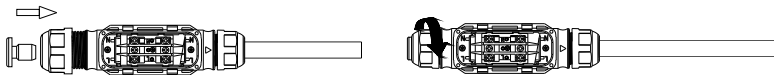

2. Crimp an EN6010 non-insulated cold-pressed terminal with each cable using a hexagonal wire crimper. Thread the cables through the cover and sealing plug. Connect the L, N and PE cables to the corresponding slots, and then tighten all screws.

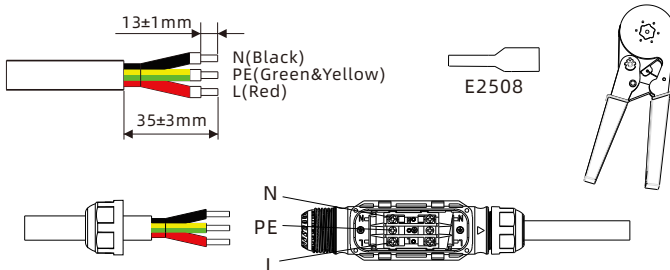

3. Tighten all screws, and tighten the cap. Install the cover back to the Trunk connector.

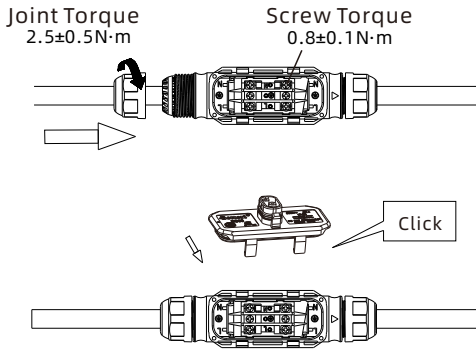

4. Attach the AC trunk cable to the mounting rack and fix the AC Trunk Connector with tie wraps.

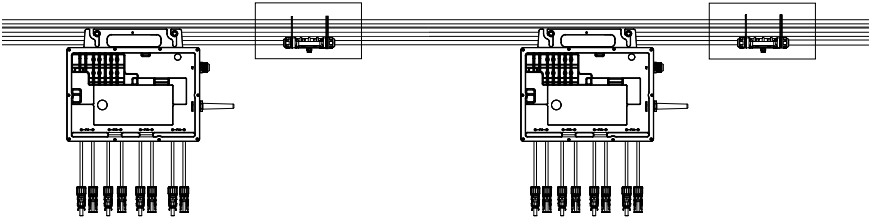

➤ Use the Male AC Sub Connector, which is applicable to the system with a single Microinverter.

a) Prepare the Male AC Sub Connector. Loosen the cover of the connector then thread the cable through the connector.

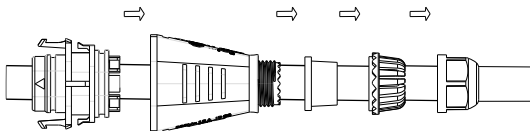

b) Strip each cable to a length of 13 mm and crimp the E2508 cord end terminal with the hexagonal wire crimper. Assign the L, N and PE cable to the corresponding slots, tighten the screws and assemble the connector.

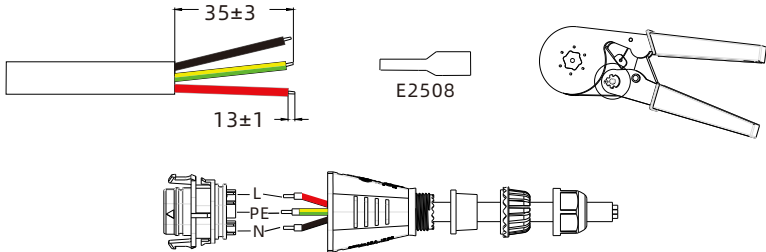

c) Fasten the nut with the AC Connector Unlock Tool.

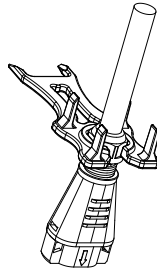

#### Step 4. Complete the AC Connection

1. Connecting multiple Microinverters using the AC Trunk Connector.

a) Push the Microinverter AC Sub Connector to the AC Trunk Connector. The connectors are coupled correctly when a click is heard. You can disconnect the AC Sub connector from the AC trunk connector using the removal tool.

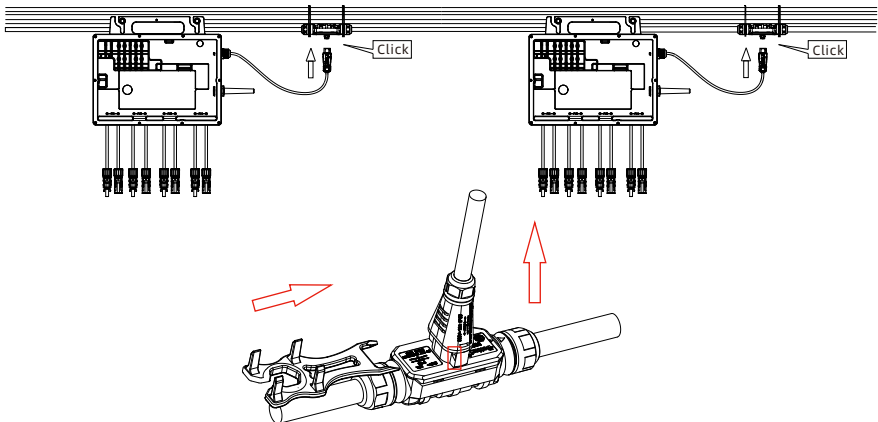

- b) Connect the AC end cable to the distribution panel, and wire it to the local grid network.
- c) Please fit the AC Trunk Port Cap on each vacant AC Trunk Port to keep them watertight and dustproof.

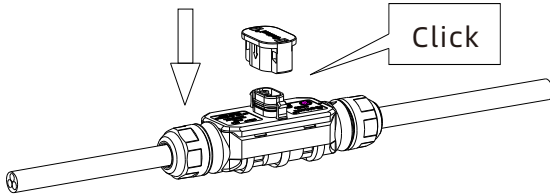

## 2. Connecting a single Microinverter using the Male AC Sub Connector.

Connect the female connector of the AC Branch Cable to the Male AC Sub Connector. Ensure that you hear the “Click” sound which indicates a reliable connection.

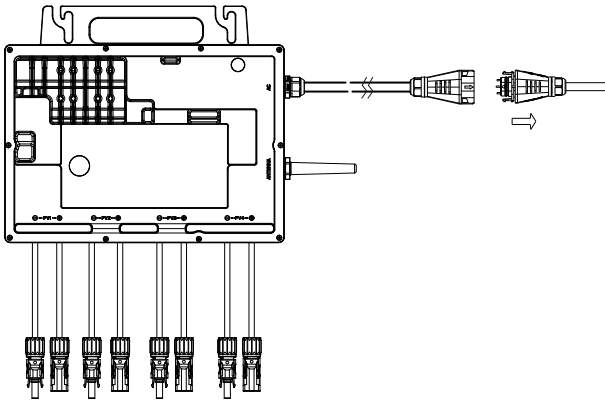

**Step 5. Create an Installation Map (Optional)**

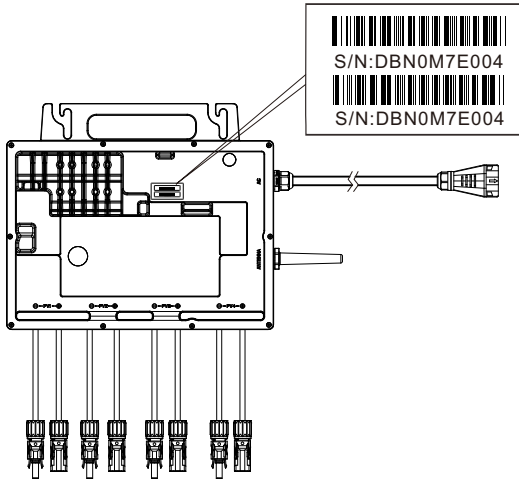

a) Peel the removable serial number label from each Microinverter.



GROWATT		Microinverter Installation Map								V1.0	
Please Make N for North		PV Array Type:				Owner:		Welink Serial Number:			
Azimuth: Tilt:		Qty:				Installer:		Date of Installation:			
		Microinverter Type:						Sheet ____ of ____			
↑ N	1	2	3	4	5	6	7	8	9	10	
A											
B											
C											
D											
E											
F											
G											
H											
J											
K											
L											

b) Stick the serial number label on the diagram (found in the appendix), according to the layout on the roof.

## Step 6. Connect the PV Module

 <p><b>NOTICE</b></p>	<p>If the DC cable is too short for installation, use the PV Extension Cable to connect PV modules to the NEO Microinverter, otherwise the PV terminals will be damaged.</p> <p>The total length of the PV cable must not exceed 5m.</p> <p>It's forbidden to connect the positive PV terminal and the negative PV terminal of one module into two different input channels. It is recommended to use the PV1-F cable.</p> <p>The DC connectors and the DC input terminals on the Microinverter must be of the same brand.</p>
 <p><b>NOTICE</b></p>	<p>The NEO Microinverter (including DC and AC connectors) should avoid direct expose to the sunlight, rain or snow. Do not place the Microinverter in the gap between PV modules. Reserve a clearance of at least 20 mm around the Microinverter to ensure sufficient space for ventilation and heat dissipation.</p> <p>The rack must be properly grounded.</p>

- Mount the PV modules above the Microinverter.
- Connect the DC cables of PV modules to the DC input ports of the Microinverter.

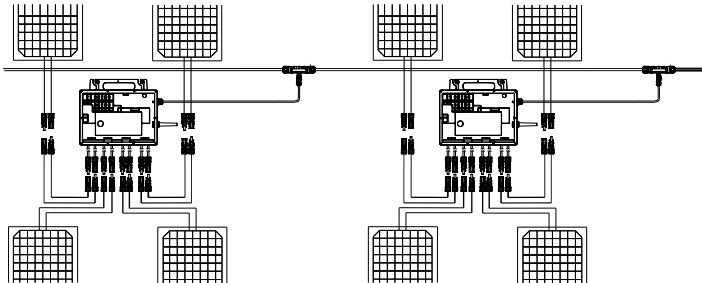

## Step 7. Power on the system

- Turn on the AC breaker of the branch circuit.
- Turn on the main AC breaker. The system will start generating power in about two minutes.

## Step 8. Set up the monitoring system

### 1. Download the APP

Method 1: Scan the QR code.

Method 2: Search for ShinePhone in Apple Store or Google Play.

**Note:** We recommend updating to the latest version when it is available.

### 2. Configure the datalogger

You can scan the QR code below to download the ShineWeLink Configuration Guide or WiFi Configuration Guide and obtain details about procedure to configure the datalogger



[ShinePhone APP]



[ShineWeLink  
Configuration Guide]



[NEO WiFi Quick  
Configuration Guide]

## Step 9. Check the installation (For qualified installer only)

No.		Check items	Y/N
1	DC	All DC connectors are connected to PV modules securely	
2	AC	The Microinverter's AC output cable is properly connected to the trunk cable	
3		Unused Sub AC ports on trunk cable are sealed with AC trunk port cap	
4		The AC trunk cable end is sealed with end cap	
5		The ground wire is properly installed (optional)	
6	Installation map	The installation map is completed (optional)	
7	Monitor	The monitoring system is working properly	

# 5 Troubleshooting



**NOTICE**

All faults will be reported to ShinePhone APP or Growatt Server Webpage. For details, please refer to Growatt Server Webpage.

Should any technical problems occur during installation and operation, qualified personnel can refer to the following instructions to rectify the fault.

## 5.1 Error Messages

An error message will be displayed on ShinePhone APP when a fault occurs. The faults can be divided into system faults and inverter faults.

Please have the following information ready when contacting Growatt support:

- Serial number
- Model number
- Error code
- Grid voltage
- DC input voltage
- Has this problem occurred in the past?
- What were the ambient conditions like when the problem occurred?

Information concerning the PV panels:

- Manufacturer and model number of the PV panel
- Output power of the panel
- Voc of the panel
- Vmp of the panel
- Imp of the panel

If it is necessary to replace the unit, please ship it in the original box.

## 5.2 System faults

System faults generally occur due to an exception in the system rather than the Microinverter. Please check the items as instructed below before replacing the inverter.

Event code	Description	Suggestion
PV Voltage High Error: 202(1-14)*	PV input voltage exceeds 60V	1. Check the voltage of each PV module with a multimeter. 2. If the voltage of the PV string is lower than 60V, please contact your dealer or Growatt customer service.

Event code	Description	Suggestion
PV Isolation Low Error: 203	Insulation problem	<ol style="list-style-type: none"> <li>1. Check if the inverter is grounded properly.</li> <li>2. Check the insulation of PV cables.</li> <li>3. Check the impedance between PV (+) &amp; PV (-) and PE cable, which must be more than <math>2K\Omega</math>. If the value is within the acceptable range and error message persists, please contact your dealer or Growatt customer service.</li> </ol>
AC V Outrange Error: 300(1~7)	300(1~3): Grid under-voltage 300(4~6): Grid over-voltage 300(7): 10-minute average over-voltage	<ol style="list-style-type: none"> <li>1. Check the AC wiring, especially the neutral and ground wires.</li> <li>2. Check if the grid voltage complies with local grid standards.</li> <li>3. Restart the inverter, if the problem persists, please contact your dealer or Growatt customer service.</li> </ol>
No AC connection Error: 302	No AC connection	<ol style="list-style-type: none"> <li>1. Check the AC wiring.</li> <li>2. Check the status of the AC breaker</li> </ol>
AC F Outrange Error: 304(1~7)	304(1/2/7): Grid under-frequency 304(3/4/6): Grid over-frequency 304(5): ROCOF Fault	<ol style="list-style-type: none"> <li>1. Check the AC wiring, especially the neutral and ground wires.</li> <li>2. Check if the grid frequency complies local grid standards.</li> <li>3. Restart the inverter. If the problem persists, please contact your dealer or Growatt customer service.</li> </ol>

### 5.3 Inverter warnings

Warning code	Description	Suggestion
Warning:220 String Disconnected (1-14)*	String1-4 Disconnected PV input voltage is lower than 5V	<ol style="list-style-type: none"> <li>1. Check the output voltage of each PV module with a multimeter.</li> <li>2. Check whether the DC connections are in poor contact.</li> </ol>
Warning:404 EEPROM abnormal	EEPROM abnormal	Restart the inverter. If the warning still exists, please contact Growatt customer service.

## 5.4 Inverter faults

Error code	Description	Suggestion
Error: 408	Over-temperature	Wait until the ambient temperature is below 65°C and restart the inverter. If the error message persists, please contact your dealer or Growatt customer service.
Error: 416	Device failure	Please contact your dealer or Growatt customer service.

Code	PV4	PV3	PV2	PV1	Note
1	0	0	0	1	PV1 Warning
2	0	0	1	0	PV2 Warning
3	0	0	1	1	PV1&PV2 Warning
4	0	1	0	0	PV3 Warning
5	0	1	0	1	PV1&PV3 Warning
6	0	1	1	0	PV2&PV3 Warning
7	0	1	1	1	PV1&PV2&PV3 Warning
8	1	0	0	0	PV4 Warning
9	1	0	0	1	PV1&PV4 Warning
10	1	0	1	0	PV2&PV4 Warning
11	1	0	1	1	PV1&PV2&PV4 Warning
12	1	1	0	0	PV3&PV4 Warning
13	1	1	0	1	PV1&PV3&PV4 Warning
14	1	1	1	0	PV2&PV3&PV4 Warning

## 5.5 LED Indicator Status

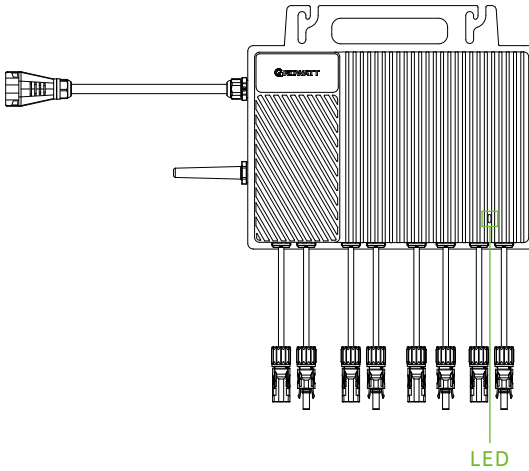

The LED indicator flashes at start-up. Steady green indicates a successful start-up.



System status	Indicator status	Description
Waiting	Flashing green (on for 1s and off for 5s)	Requirements are not met: PV voltage is not within the start-up range; phase locking fails; grid voltage or frequency is not within the permissible range.
Countdown for grid-connection	Flashing green (on for 1s and off for 1s)	When the requirements are met, the Microinverter will count down to connect to the grid.
Grid-tied	Steady green	Successfully connected to the grid and the router.
	Flashing green (on for 5s and off for 5s)	Successfully connected to the grid, but failed to connect to the router.
Fault	Steady red	Hardware damaged.
	Flashing red (on for 1s and off for 1s)	Recoverable fault caused by the field environment.
Programming	Flashing yellow and green (on for 1s and off for 1s)	Update firmware online.

The Microinverter is powered by PV modules. If the LED indicator is off, please check the DC side connection. If the connection is correct and the PV voltage is higher than 16V, contact your distributor or Growatt customer service.

## 5.6 Microinverter Replacement

 <p><b>WARNING</b></p>	<ul style="list-style-type: none"><li>➤ Do not attempt to repair the Microinverter by yourself. Please contact your local customer service for technical support.</li><li>➤ Never disconnect the PV connectors under load. Ensure that no current presents in the DC cables prior to disconnecting.</li><li>➤ Always disconnect the AC breaker before disconnecting the PV module from the Microinverter.</li></ul>
 <p><b>CAUTION</b></p>	<p>Danger of burn injuries due to hot enclosure parts!</p> <ul style="list-style-type: none"><li>➤ Wait 15 minutes before removing the Microinverter until the enclosure cools down.</li></ul>

a) If the microinverter replacement is authorized, perform the following steps:

1. Turn off the branch circuit breaker.
2. Remove the PV module from the rack and cover the module.
3. Disconnect the AC Sub Connector from the AC Trunk Connector with the AC Connector Unlock Tool.

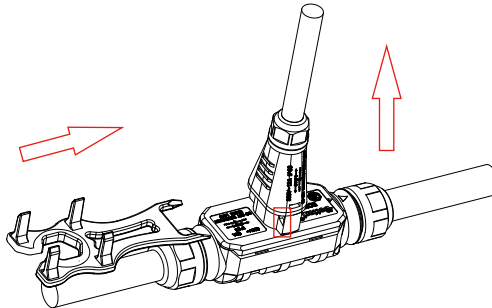

4. Disconnect the PV module DC wire connectors from the Microinverter.
- b) Install a replacement unit to the rack.
- c) Connect the AC Sub Connector of the replacement unit to the AC Trunk Connector.
- d) Close the branch circuit breaker and check the operation status of the replacement unit.
- e) Add the new device on the ShinePhone APP or the Growatt Server Webpage to update the relevant information. Replace the label with the serial number of the new unit on the installation map.

# Warranty 6

Please refer to the warranty card or other relevant documents.

# 7 Decommissioning

## 7.1 Removing the Microinverter

1. Disconnect the Microinverter from all power sources.
2. Remove all cables connected to the Microinverter.
3. Remove the microinverter from the rack.

## 7.2 Packing the Microinverter

If the original packing box is available, please put the Microinverter in its original carton and secure it with tension belts. If it is no longer available, you can also use an equivalent carton. The box must be capable of being closed completely and made to support both the weight and the size of the inverter.

## 7.3 Storage and Transportation

To store or transport the NEO Microinverter, it is recommended to place it in the original packing carton. A maximum of 4 carton boxes can be stacked.

- If you opt to store the Microinverter in your warehouse, please select an appropriate location. The storage temperature should be always between -40°C and +65°C. Keep the storage relative humidity lower than 95%.
- After long-term storage, the local installer or personnel from Growatt service department should perform a comprehensive test before installation.

## 7.4 Disposal



Do not dispose of faulty Microinverters or accessories together with household waste. Please comply with the disposal regulations for electronic waste which apply at the installation site.

# Technical Data 8

## 8.1 Specifications

Model Specifications	NEO	NEO	NEO	NEO	NEO
	1600M-X2	1800M-X2	2000M-X2	2250M-X2	2500M-X2
Input data(DC)					
Max. DC voltage	60V				
Start-up voltage	20V				
MPP voltage range	16-55V				
No. of MPP trackers	4				
No. of PV module per MPP tracker	1/1/1/1				
Max. input current per MPP tracker	18A				
Max. short-circuit current per MPP tracker	20A				
Output data(AC)					
AC nominal power	1600W	1800W	2000W	2250W	2500W
Max. AC apparent power	1600VA	1800VA	2000VA	2250VA	2500VA
Nominal AC voltage/range*	220V/230V/240V 180V~275V				
AC grid frequency/range*	50Hz/60Hz 45Hz~55Hz;55Hz~65Hz				
Rated output current	7.27a.c.A @220a.c.V 6.96a.c.A @230 a.c.V 6.67a.c.A @240a.c.V	8.18a.c.A @220a.c.V 7.83a.c.A @230 a.c.V 7.5a.c.A @240a.c.V	9.09a.c.A @220a.c.V 8.70a.c.A @230 a.c.V 8.33a.c.A @240a.c.V	10.23a.c.A@ 220a.c.V 9.78a.c.A@2 30 a.c.V 9.38a.c.A @240a.c.V	11.36a.c.A@ 220a.c.V 10.87a.c.A@ 230 a.c.V 10.42a.c.A @240a.c.V
Max. output current	7.27A	8.18A	9.09A	10.23A	11.36A
Max. inverter backfeed current to the PV array	0A				
Power factor (@nominal power)	>0.99				
THDi	<3%				
AC grid connection type	Single phase				

<b>Model</b>	<b>NEO 1600M-X2</b>	<b>NEO 1800M-X2</b>	<b>NEO 2000M-X2</b>	<b>NEO 2250M-X2</b>	<b>NEO 2500M-X2</b>
<b>Specifications</b>					
Overvoltage category	PV:II AC:III				
<b>Efficiency</b>					
Max. efficiency	96.5%				
CEC efficiency	96%				
MPPT efficiency	99.5%				
<b>Protection</b>					
DC reverse-polarity protection	Integrated				
AC surge protection	Type III				
AC short-circuit protection	Integrated				
Grid monitoring	Integrated				
Anti-islanding protection	Integrated				
<b>General data</b>					
Dimensions (W/H/D)	396mm×270mm×45mm				
Weight	5.1kg				
Operating temperature range	-40 °C ~ +65°C				
Noise emission (typical)	≤ 25 dB(A)				
Max. altitude	4000m				
Night Power Consumption	50mW				
Topology	Isolated				
Cooling	Natural convection				
Protection degree	IP67(NEMA 6)				
Relative humidity	0~100%				
DC connection	VP-D4/ MC4(opt)				
AC connection	Quick connector				
<b>Interfaces</b>					
Display	LED+APP				

<b>Model</b>	<b>NEO 1600M-X2</b>	<b>NEO 1800M-X2</b>	<b>NEO 2000M-X2</b>	<b>NEO 2250M-X2</b>	<b>NEO 2500M-X2</b>
<b>Specifications</b>					
WiFi/LoRa	Optional				
Warranty:12/15years	Yes/Optional				
<b>Wireless parameters(2.4GHz WiFi)</b>					
Wireless standard	802.11 b/g/n				
Wireless frequency	2412-2472MHz				
Maximum output power	+20dBm				
Encryption scheme	AES				
<b>Wireless parameters(LoRa)</b>					
Wireless frequency	868 MHz (EU) / 915 MHz				
Maximum output power	14dBm (EU) / 17dBm				
<b>Certificates and approvals</b>					
Grid regulation	N4105; EN 50549-1/10; UNE 217002,NTS Type A;C10, C11; G98; CEI 0-21;TOR;NC RfG IEEE1547; ORDINANCE NO.140				
Safety	CE(EMC;LVD;RED); UL1741; IEC/EN62109-1, IEC/EN62109-2; IEC/EN 62920, IEC/EN 61000-6-1 / -2/-3/-4; IEC/EN 61000-3-2/-3				
Communication	Incorporates product approved by Anatel under number 09146-24-10174				
Place of production	Made in China				

All specifications are subject to change without notice.

\* The AC Voltage and Frequency Range may vary depending on specific country grid standard.

## 8.2 DC connector info

DC connector	VP-D4/ MC4(opt)
--------------	-----------------

## 8.3 Torque

AC Trunk Connector	2.5 N·m
Grounding Screw	0.8 N·m

# 9 Declaration of conformity

This product complies with the following regulations and requirements:

- Electromagnetic Compatibility Directive:2014/30/EU (EMC)
- Radio equipment instruction:2014/53/EU(RED)
- Electrical Equipment (Safety) Regulations 2016:2014/35/EU(LVD)
- Restriction of Hazardous Substances Directive: 2011/65/EU(EU) and 2015/863 (RoHS)

You can download the Declaration of Conformity at

[https://en.growatt.com/upload/file/EU\\_Conformity\\_Declaration\\_NEO\\_1600\\_2500M\\_X2.pdf](https://en.growatt.com/upload/file/EU_Conformity_Declaration_NEO_1600_2500M_X2.pdf)

# Contact 10

Find contact info for worldwide after-sales service at <https://en.growatt.com/support/contact>.

**Shenzhen Growatt New Energy Co., Ltd.**

4-13/F, Building A, Sino-German (Europe) Industrial Park,  
Hangcheng Blvd, Bao'an District, Shenzhen, China

**T** +86 755 2747 1942

**E** [service@ginverter.com](mailto:service@ginverter.com)

**W** [en.growatt.com](http://en.growatt.com)



 [Growatt New Energy](#)

Download  
Manual

Shenzhen Growatt New Energy Co., Ltd.  
4-13/F, Building A, Sino-German (Europe) Industrial Park,  
Hangcheng Blvd, Bao'an District, Shenzhen, China

T +86 755 2747 1942  
E [service@ginverter.com](mailto:service@ginverter.com)  
W [en.growatt.com](http://en.growatt.com)

GR-UM-449-A-01 (PN:044.0138001)